

Product Guide

IP65 Rated Humidistat

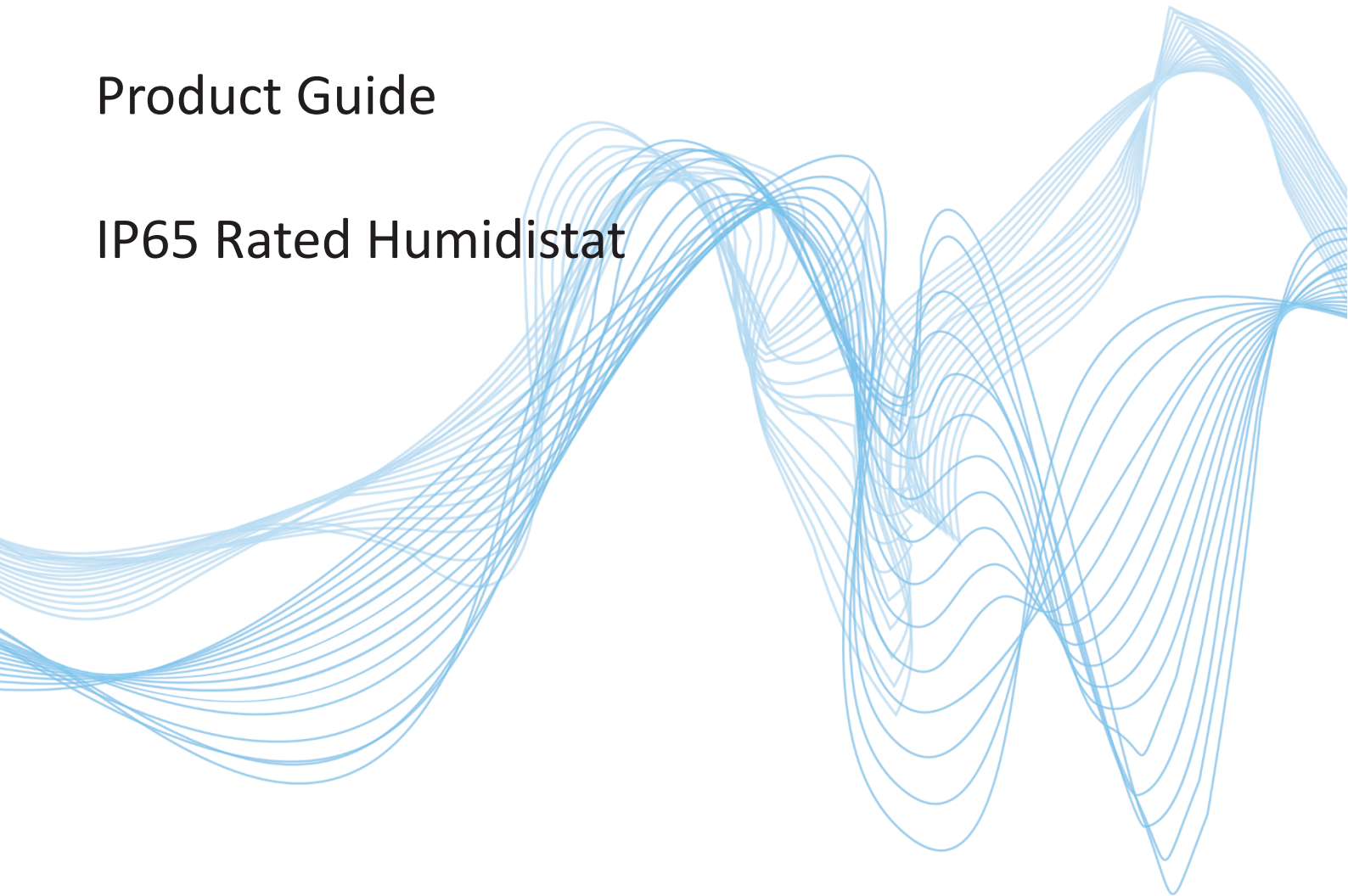

today, tomorrow and in the future

mselectronics.co.uk

Product Overview

The IP65H utilises an IP65 rated polycarbonate enclosure with an embedded high accuracy temperature sensor to control heating or air conditioning. A built-in M20 cable gland maintains the IP65 rating when used with appropriate electrical cable.

The IP65H regulates to a fully adjustable relative humidity set-point between 5% and 95%, combined with an adjustable relative humidity hysteresis (differential) of anything between 1% and 10%.

Product Wiring

- IMPORTANT:** ensure all electrical connections are isolated before commencing any work on the unit.
- Power to the humidistat is provided via the Live and Neutral input terminals labelled “L” and “N” (230V AC, 50Hz).
- A voltage-free changeover relay output capable of switching loads of up to 10A, 250V AC (resistive) is provided by the humidistat. Connect to your application in an appropriate manner given the following:
 - The Common “COM” terminal is connected to the Normally Open “NO” terminal when the sensed relative humidity is above the “Setpoint” humidity. (Use to control dehumidification equipment, including air conditioners.)
 - Conversely, the “COM” terminal is connected to the Normally Closed “NC” terminal when the relative humidity is sensed to be below the “Setpoint” humidity. (Use to control humidification equipment.)

Figure 1 Typical wiring example

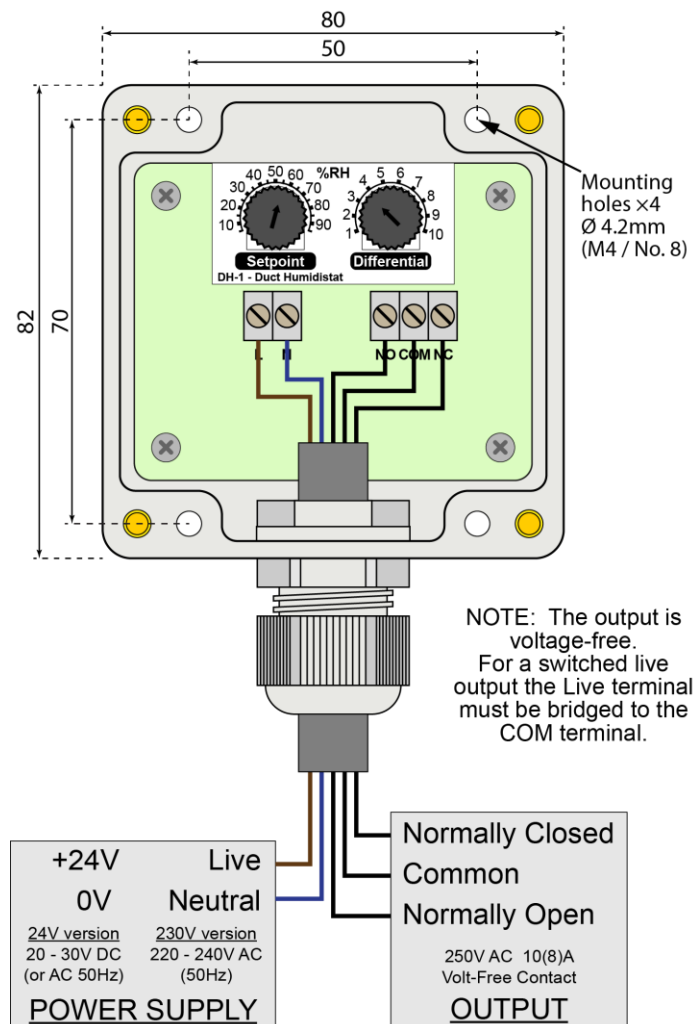

Installation

1. **IMPORTANT:** ensure all electrical connections are isolated before commencing any work on the unit.
2. Unscrew and remove the front of the enclosure which contains the electronics.
3. Mount the rear of the enclosure to the wall using the 4 pre-existing screw points. DO NOT drill through the back of the enclosure as this will void the product IP rating.
4. Ensure best-practices are used when choosing a location for the thermostat so that optimal thermostatic control is achieved. Do not mount near drafts, heaters, radiators, air conditioners, in direct sunlight or any other place where the sensed temperature may be unnaturally influenced. A good mounting height is typically between 1m and 2m from the floor.
5. Pass the electrical cable through the cable gland then connect as shown in Figure 1 (or any suitably appropriate form). Ensure the correct output terminals that are suitable to your application are chosen.
6. Adjust the internal thumbwheels to suit the desired operational requirements (see below).
7. Before replacing the cover, securely connect its flying lead to the Front Panel connector.
8. Reattach the cover securely, alternating between screws in opposite corners to create an even seal.
9. **IMPORTANT:** ensure that the sensor is not installed in a position where it is likely to get water sitting on it at any time. If water is allowed to sit on the sensor this will give false humidity readings.

Operation

1. **IMPORTANT:** ensure all electrical connections are isolated before commencing any work on the unit.
2. Adjust the "Setpoint" dial to the relative humidity the duct air is to be regulated to.
3. Set the "Differential" to the total relative humidity swing either side of the "Setpoint" that the duct air humidity is required to keep within.
4. Example of a typical set-up:
 - Setpoint set to 55% RH, Differential set to 4% RH.
 - The unit will maintain the relative humidity between 53% RH and 57% RH.

Technical Specification	
Power supply:	220V - 240V AC 50Hz (live/neutral) 22V - 24V AC or DC ("/24V" variant only)
Output switch rating:	10A, 250V AC 50Hz (resistive)
Output switch type:	Changeover relay (volt-free)
Humidity control:	5% RH to 95% RH
Humidity differential:	1% RH to 10% RH
Sensor accuracy:	+/- 3% RH
Sensor drift:	+/- 1.2% RH over 5 years (no calibration required)
Guarantee:	3 Years
Weight:	190g
Dimensions:	82mm x 80mm x 55mm

IMPORTANT INSTALLATION NOTICE

The installation of this product should be carried out in accordance with the latest IEE wiring regulations and all wiring completed by a qualified electrician.

Technical Support

For further help or information on this and the other products in the MS Electronics range visit www.mselectronics.co.uk or call 0333 666 1176.

Alternatively, email techsupport@mselectronics.co.uk

Additional copies of this product guide can be downloaded from our website.

Product Warranty

MS Electronics guarantees all their products against manufacturing defects for 3 years from the purchase date. If your product is found to be faulty, MS Electronics will, at their discretion, repair or replace the product free of charge.

Note

Any modification or damage to the outer casing of the product, as well as any damage to the product due to abuse or incorrect wiring may invalidate the guarantee.

e: info@mselectronics.co.uk

t: 0333 666 1176/01708 448566

