

Product Guide

Two-Stage Robust Thermostat with remotely activated set-back

(modified 2nd stage functionality)

today, tomorrow and in the future

mselectronics.co.uk

Product Overview

The E810/M2S is a 2-stage thermostat with a remotely controlled set-back functionality, offering a high quality and robust solution to tamperproof energy-saving thermostatic control. It utilises a high-accuracy radiant heat sensor in conjunction with its die-cast aluminium case and tamperproof screws to ensure vandal-resistant yet accurate tamperproof energy control.

The E810/M2S regulates to a fully adjustable temperature Setpoint between +12°C and +26°C, combined with an adjustable temperature hysteresis (differential) of anything between 0.25°C and 4°C. Additionally an adjustable Set-Back (°C back from the Setpoint) of up to 14°C can be applied. A PIR motion sensor or timeclock is typically used to activate the remote input which selects between the Setpoint or Set-Back temperatures ('High' when the switch is closed and 'Low' when the switch is open). This ensures the room temperature is regulated to a comfortable level when it is occupied yet significantly reduces heating energy consumption when the room is empty.

2-stage functionality is used to select between two different fan speeds when the E810/M2S controls the heating device (often a multi-speed fan convector). The High fan speed is activated upon the thermostat detecting the remote switch being closed, such as when the room first becomes occupied. This allows the room temperature to boost up to the target level quickly using the High fan speed. Once the target temperature is reached the fan is turned Off and the Low fan speed is selected thereafter to keep the room temperature constant. See Figure 1 for a graphical representation.

This 2-stage functionality ensures the room temperature quickly raises when it becomes occupied or a specific time of day is reached, and will then switch to a much quieter mode of operation once the room temperature is up to the desired level, or the room becomes unoccupied. This functionality makes the 2-stage thermostat ideally suited to areas such as classrooms where a quick initial response is required, but quiet operation is required thereafter.

Figure 1: Functionality Diagram

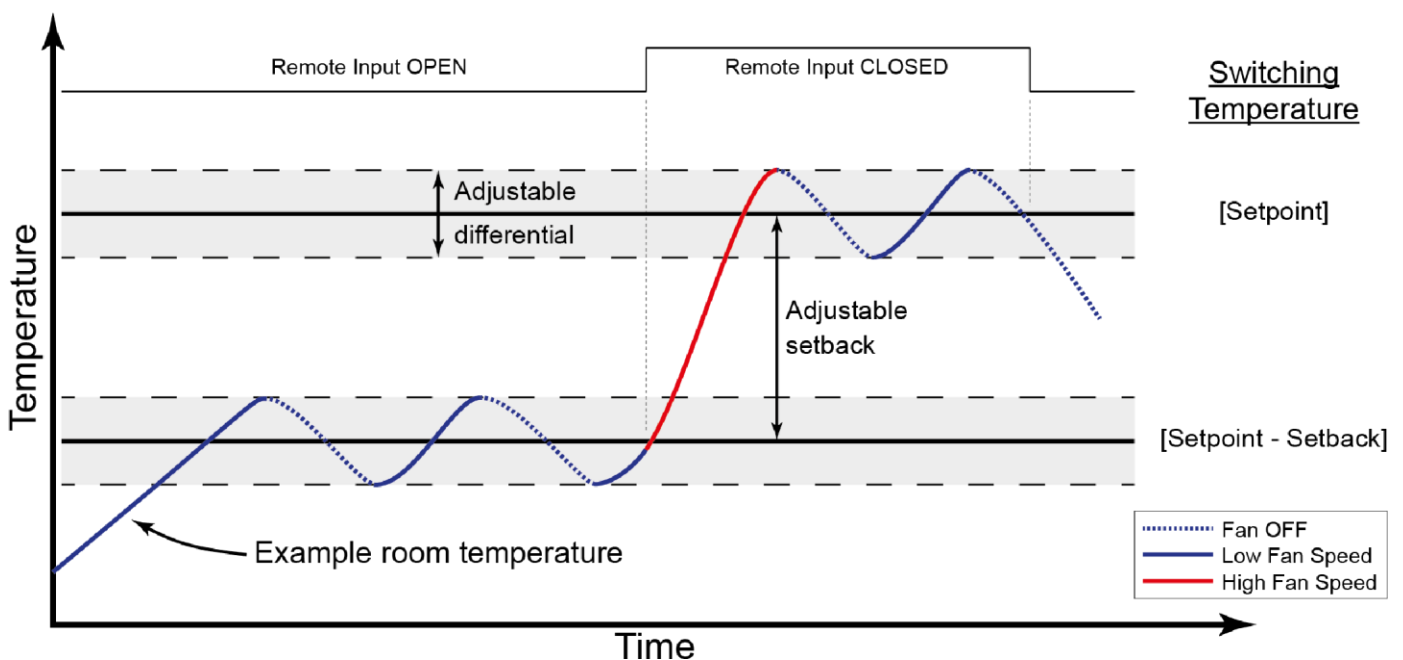

Product Wiring

1. **IMPORTANT:** ensure all electrical connections are isolated before commencing any work on the unit.
2. Power to the thermostat is provided via the Live and Neutral input terminals labelled “L” and “N” (85 - 265V AC, 50 - 60Hz).
3. **NOTE:** This thermostat MUST be earthed using the earth terminal provided.
4. Two voltage-free relay outputs capable of switching loads of up to 10A, 250V AC (resistive) are provided by the thermostat for controlling a fan convector.
5. The “FAN” terminal is connected to the “HI” terminal when the thermostat has selected the High fan speed, conversely, it is connected to the “LO” terminal when the Low fan speed is selected.
6. The “COM” terminal is connected to the “TX” terminal when the fan is to be On, conversely it is disconnected when the fan is to be Off.
7. The “Remote Switch” input selects the ‘High’ Set-Back mode when it is closed and the ‘Low’ Set-Back mode when it is open.
8. The temperature sensor is factory fitted to all models with the exception of the Remote Sensor (/RS) versions. A 2-core screened cable connection should be made to the “Temp. Sensor” terminals on /RS versions, with the screen connected to the thermostat Earth terminal only.
9. **CAUTION:** The remote switch and temperature sensor inputs are not electrically isolated from the thermostat mains supply and so could possibly be at mains potential. Treat the inputs with the necessary safety and insulation precautions as if they were at mains potential.

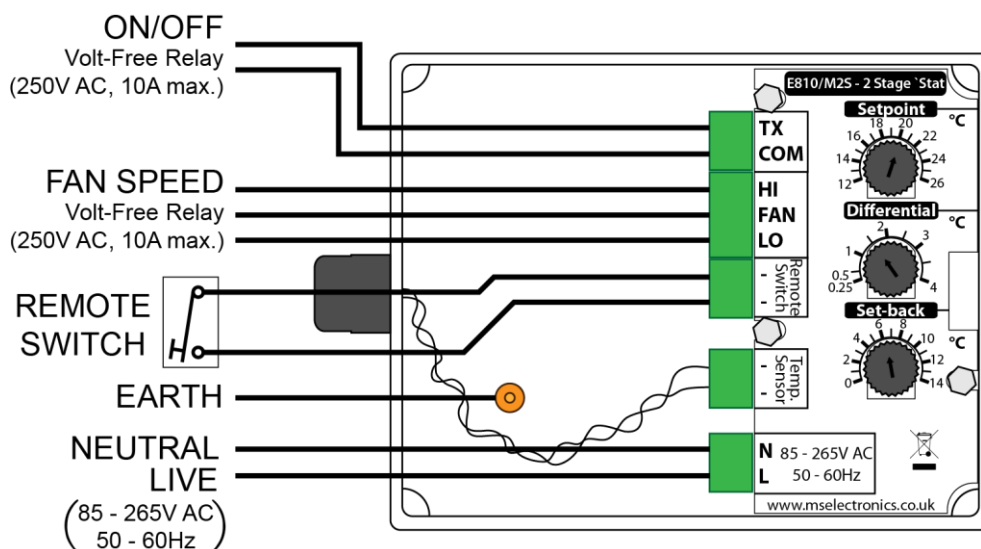

Figure 2: Typical Wiring Diagram

Installation

1. **IMPORTANT:** ensure all electrical connections are isolated before commencing any work on the unit.
2. Unscrew the 4 security screws using M.S. Electronics tamperproof screwdriver MSD-152 to remove the front cover.
3. Mount the unit securely using any suitable fixing in conjunction with the mounting holes provided in the unit. For optimal results, position the temperature sensor out of direct sunlight and well away from any heating/cooling sources.
4. Using Figures 2 to 5 as a guide, connect the wiring in a suitably appropriate form with the convenient pluggable terminal blocks provided. Contact Technical Support with the heater make and model number for specific help if a suitable wiring method is unclear.
5. On the remote sensor version, 2-core screened cable should be used to connect the remote sensor to the thermostat. The screen should be connected to the earth terminal ONLY (do not connect the screen to anything at the remote sensor end).
6. Adjust the internal controls to suit the operational requirements (see the ‘Operation’ section).
7. Replace the cover securely using the 4 security screws.

Typical Fan Convector Wiring Examples

The diagrams in Figures 3 to 5 illustrate a few generic methods of how to electrically connect the thermostat to a multi-speed fan convector. If you are unsure which of the below diagrams is most suited to your application, please contact our Technical Support team with the specific make and model of heater for further assistance.

Note: The heater may have more than 2 speeds, however the E810/M2S can only control a maximum of 2 speeds (plus 'Off'). When selecting the low fan speed, ensure that in the worst case there is still sufficient heat output to maintain the desired room temperature. A medium speed may need to be selected for the low speed in some cases.

Figure 3: Hot water fan convector (a)

The transformer and the fan are in the same module.
The thermostat routes the Live supply to the correct speed selection terminal on the heater.

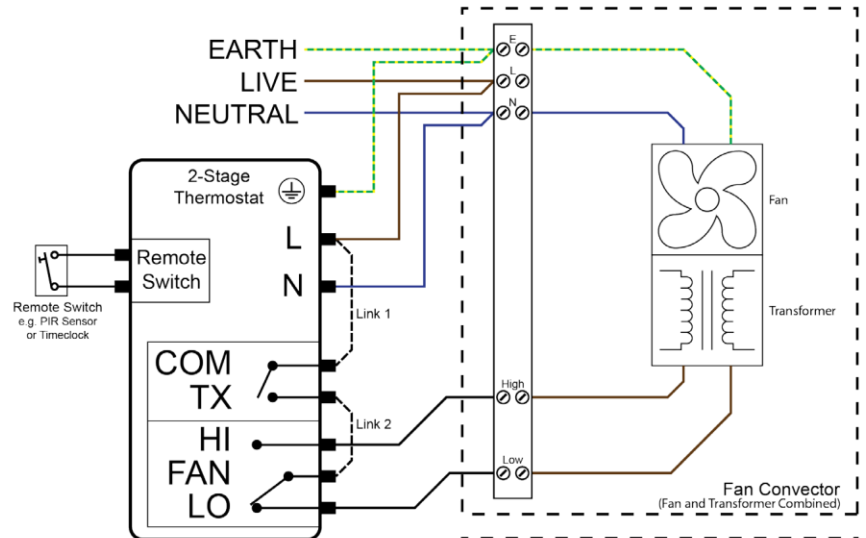

Figure 4: Hot water fan convector (b)

The transformer and the fan are in separate modules.
The transformer has different speed outputs. The thermostat routes the correct speed directly to the fan.

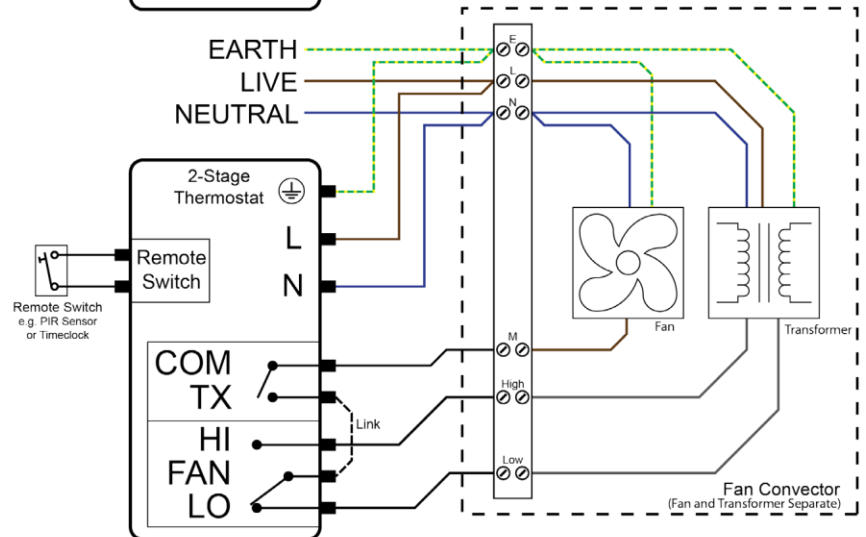
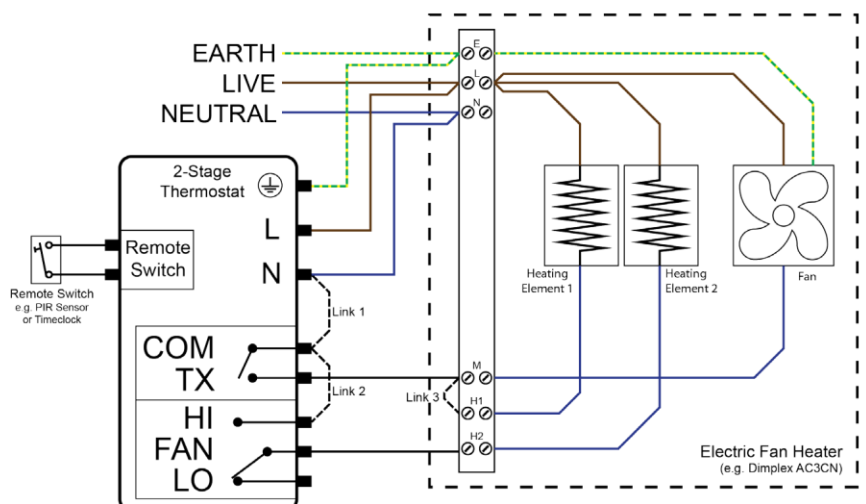

Figure 5:

Rather than changing fan speeds the thermostat correctly selects either 1 heating element + fan, or 2 heating elements + fan.



Operation

1. **IMPORTANT:** ensure all electrical connections are isolated before commencing any work on the unit.
2. Adjust the “Setpoint” dial to the temperature the room is to be regulated at when in HIGH mode (typically 21°C).
3. Set the “Differential” to the total temperature swing either side of the “Setpoint” that the room temperature is required to keep within (typically 1°C).
4. Adjust the “Set-Back” to the temperature below the HIGH “Setpoint” to obtain the desired temperature in LOW mode.

Example of a typical set-up:

“Setpoint” set to 22°C, “Differential” set to 1°C and “Set-Back” set to 4°C.

HIGH mode (Remote Switch input CLOSED) (**RED** LED):

The unit will maintain the temperature between 21.5°C and 22.5°C.

The High fan speed will be selected upon first entering this mode.

The Low fan speed will be selected once the target temperature is reached.

LOW mode (Remote Switch input OPEN) (**GREEN** LED):

The unit will maintain the temperature between 17.5°C and 18.5°C.

The Low fan speed will always be selected in this mode.

Technical Specification	
Power supply:	85V - 265V AC 50 - 60Hz (live/neutral/earth)
Output switch rating:	10A, 250V AC (resistive)
Output switch type:	On/Off: Single contact relay (volt-free) High/Low: Changeover relay (volt-free)
Temperature control:	[high Setpoint]: +12°C to +26°C [low Setpoint]: 0°C to 14°C below the high Setpoint
Temperature differential:	0.25°C to 4°C
2-stage control:	2 speeds (High/Low) + Off
Sensor drift:	0.15°C over 5 years
Guarantee:	3 Years
Weight:	0.34Kg
Dimensions mm:	120mm x 95mm x 35mm

Product Accessories	
MSD-152	M.S. Electronics tamperproof screwdriver
MSD-150	Air temperature sensor (sensor only)
MSD-224	Air temperature sensor (internal, boxed)
MSD-370	Air temperature sensor (internal, faceplate)

IMPORTANT INSTALLATION NOTICE

The installation of this product should be carried out in accordance with the latest IEE wiring regulations and all wiring completed by a qualified electrician.

Technical Support

For further help or information on this and the other products in the MS Electronics range visit www.mselectronics.co.uk or call 0333 666 1176.

Alternatively, email techsupport@mselectronics.co.uk

Additional copies of this product guide can be downloaded from our website.

Product Warranty

MS Electronics guarantees all their products against manufacturing defects for 3 years from the purchase date. If your product is found to be faulty, MS Electronics will, at their discretion, repair or replace the product free of charge.

Note

Any modification or damage to the outer casing of the product, as well as any damage to the product due to abuse or incorrect wiring may invalidate the guarantee.

e: info@mselectronics.co.uk

t: 0333 666 1176/01708 448566



MS Electronics reserves the right to alter or change this specification without prior notice.