

Product Guide

Duct Thermostat

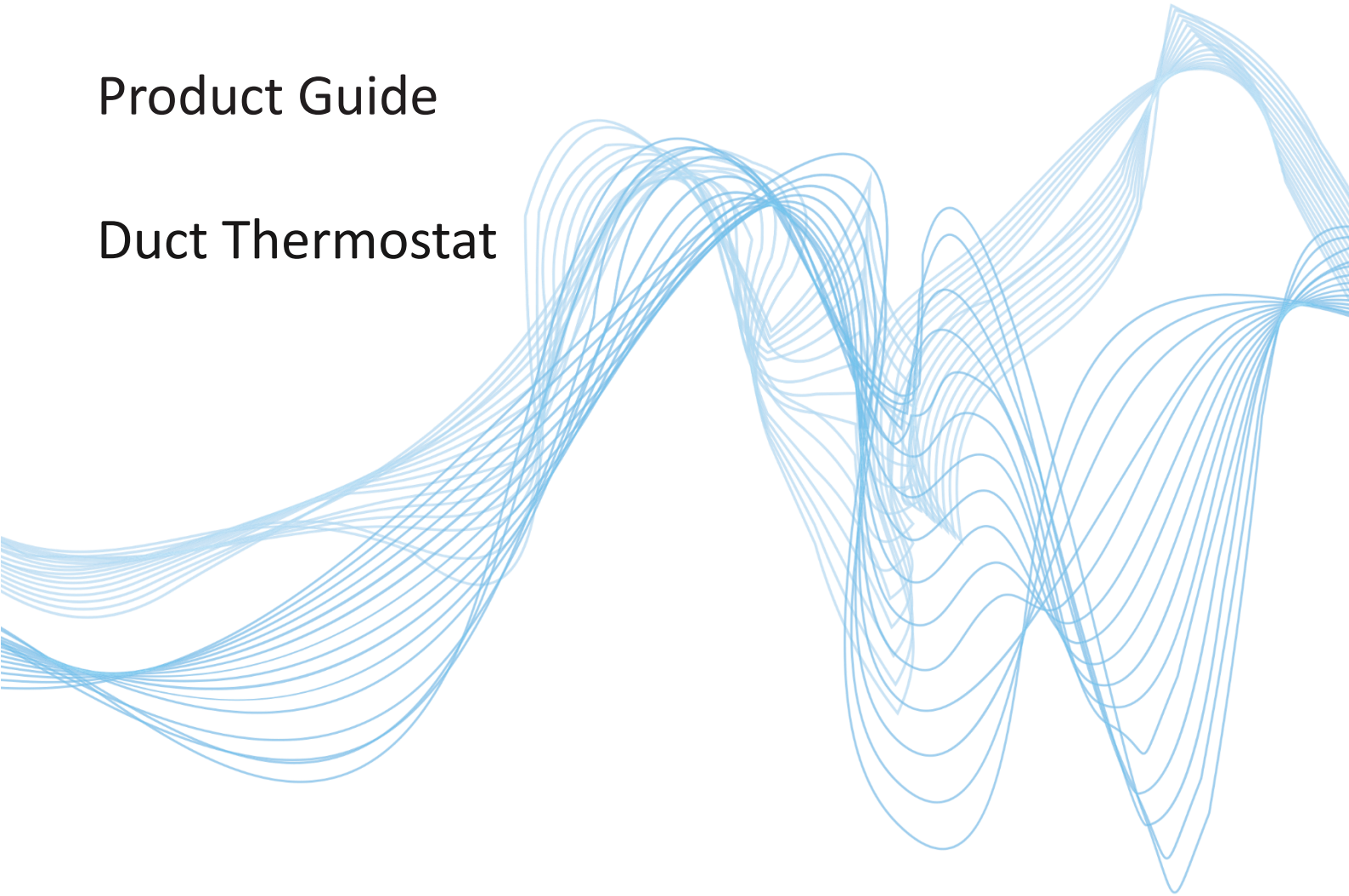

today, tomorrow and in the future

mselectronics.co.uk

Product Overview

The DT-1/24V duct thermostat offers a calibration-free, high accuracy and high quality solution to thermostatic control of duct airflow in heating, ventilation and air conditioning (HVAC) systems. The unit is powered from a 24V AC or DC supply and mounts directly on to the outside of the ductwork, with the temperature sensing probe projecting into the duct.

The DT-1/24V regulates to a fully adjustable temperature set-point between +12°C and +26°C, combined with an adjustable temperature hysteresis (differential) of anything between 0.25°C and 4°C.

Product Wiring

- IMPORTANT:** ensure all electrical connections are isolated before commencing any work on the unit.
- Power to the thermostat is provided via the 24V AC/DC input terminals. No specific polarity is necessary on the power connections.
- A voltage-free changeover relay output capable of switching loads of up to 10A, 250V AC (resistive) is provided by the thermostat. Connect to your application in an appropriate manner given the following:
 - The Common "COM" terminal is connected to the Normally Closed "NC" terminal when the temperature is sensed to be above the "Setpoint" temperature. (Use to control cooling equipment.)
 - Conversely, the "COM" terminal is connected to the Normally Open "NO" terminal when the temperature is sensed to be below the "Setpoint" temperature. (Use to control heating equipment.)

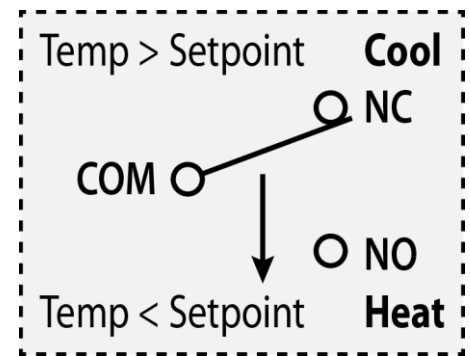
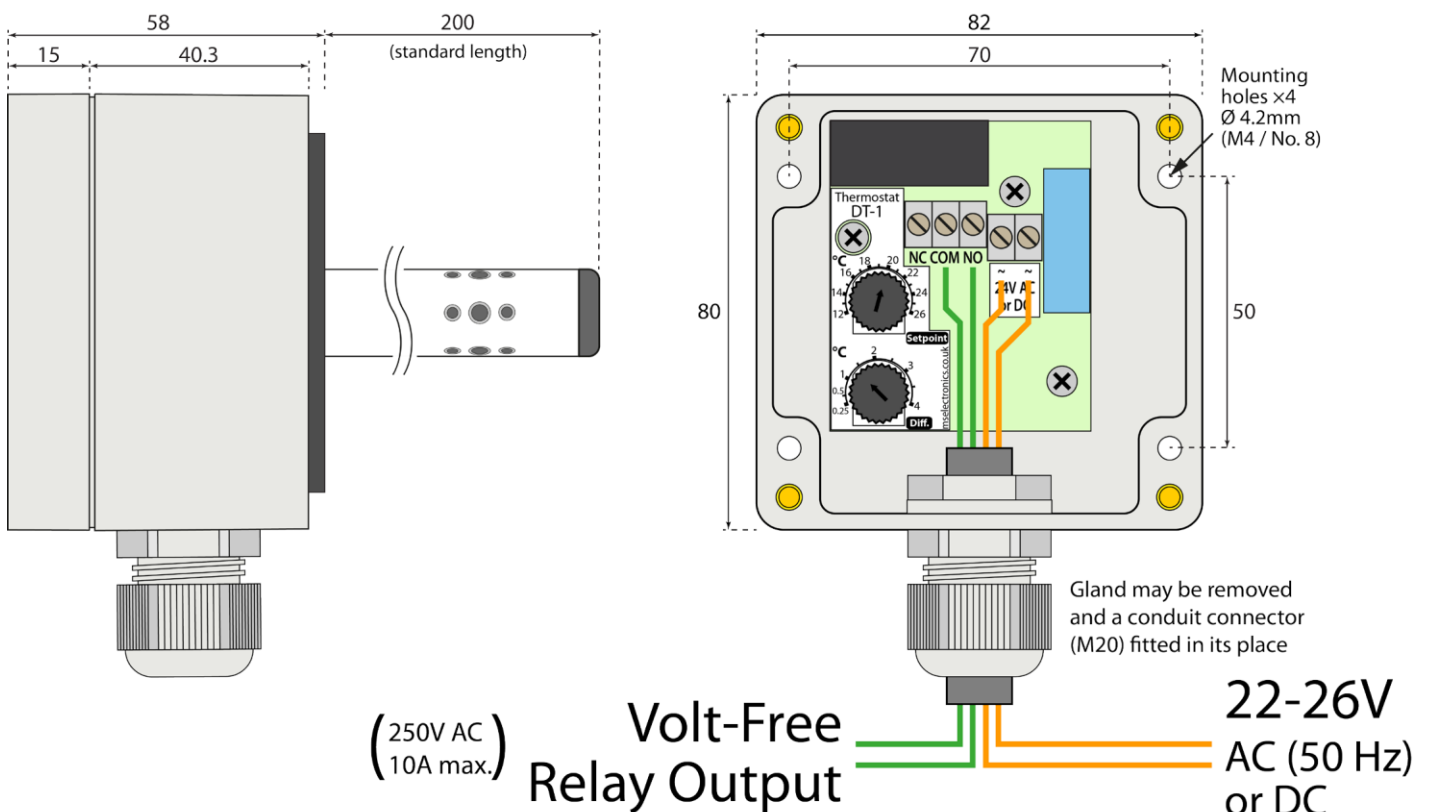

Figure 1 Typical wiring example (for heating)



Installation



All electrical installation and maintenance must be carried out by qualified personnel in accordance with the current edition of the IET Wiring Regulations (BS7671).

1. Identify a suitable location on the ductwork exterior, preferably where the duct air is cleanest (after filtration elements). Mark and drill a 16mm (minimum) diameter hole in the duct through which the probe will enter. Any existing hole of up to 25mm is also suitable.
2. Remove the lid of the unit and place the probe through the hole, with the unit flat to the ductwork and centred in the hole. Mark the four mounting positions (indicated in Figure 1).
3. Drill appropriate pilot holes, and secure the unit to the duct with suitable self-tapping screws.
4. Adjust the internal controls to suit the installation operational requirements (see below).
5. Wiring to the unit should run through the preinstalled cable gland. Alternatively, if a direct connection to electrical conduit is desired, a suitable conduit connector may be fitted.

If using gland: For cable outer diameters of 5 to 7.5mm, use the gland as provided. For larger cables (up to 13mm), remove the outer nut of the gland, withdraw the rubber insert, separate the two parts and reinsert just the outer ring. The other part may be discarded.

If using conduit: Remove the cable gland by holding the internal locknut steady and unscrewing the outer part. Fit an appropriate conduit connector (with M20 thread) in its place.

6. Connect the wiring to the terminal blocks on the thermostat as shown in Figure 1 (or in any suitably appropriate form). Make sure to choose the correct output terminals that are suitable to your application.
7. Tighten the cable gland or conduit connector onto the outer sheath of the cable.
8. Replace the lid and securely tighten the screws.

Operation



Ensure the electrical supply to the unit is isolated before making any adjustments.

1. Adjust the “Setpoint” dial to the temperature the duct air is to be regulated to.
2. Set the “Differential” to the total temperature swing either side of the “Setpoint” that the duct air temperature is required to keep within.
3. Example of a typical set-up:
Setpoint set to 20°C, Differential set to 1°C.
The unit will maintain the temperature between 19.5°C and 20.5°C.
4. In clean airflow, the unit should require no maintenance. If necessary, the unit may be released from the duct and any accumulated debris blown or vacuumed from the probe grille.

Technical Specification

Power supply:	22V - 26V AC (50Hz) or DC
Output switch rating:	10A, 250V AC 50Hz (resistive)
Output switch type:	Changeover relay (volt-free)
Cable entry:	Pre-fitted M20 gland, for 5 to 13mm dia. round cable (remove reducer insert for >7.5mm). May be exchanged for a M20 conduit connector
Temperature control:	+12°C to +26°C
Temperature differential:	0.25°C to 4°C
Sensor accuracy:	±0.2°C
Sensor drift:	0.15°C over 5 years
Probe length (standard):	200mm (sensing element 178mm from base)
Guarantee:	3 Years
Weight:	210g
Dimensions (with standard probe):	109mm x 82mm x 258mm

IMPORTANT INSTALLATION NOTICE

The installation of this product should be carried out in accordance with the latest IEE wiring regulations and all wiring completed by a qualified electrician.

Technical Support

For further help or information on this and the other products in the MS Electronics range visit www.mselectronics.co.uk or call 0333 666 1176.

Alternatively, email techsupport@mselectronics.co.uk

Additional copies of this product guide can be downloaded from our website.

Product Warranty

MS Electronics guarantees all their products against manufacturing defects for 3 years from the purchase date. If your product is found to be faulty, MS Electronics will, at their discretion, repair or replace the product free of charge.

Note

Any modification or damage to the outer casing of the product, as well as any damage to the product due to abuse or incorrect wiring may invalidate the guarantee.

e: info@mselectronics.co.uk

t: 0333 666 1176/01708 448566



MS Electronics reserves the right to alter or change this specification without prior notice.