

Product Guide

Set-Back Robust Thermostat



today, tomorrow and in the future

mselectronics.co.uk

Product Overview

The E816 offers a high quality and robust solution to tamperproof energy saving thermostatic control. It utilises a high-accuracy radiant heat sensor in conjunction with its die-cast aluminium case and tamperproof screws to ensure vandal-resistant, yet accurate tamperproof energy control.

The E816 is a standard set-back thermostat with a set-point between +12°C and +26°C, combined with an adjustable temperature hysteresis (differential) of anything between 0.25°C and 5°C and a set-back of up to 14°C. The thermostat regulates to one of two preset temperatures which can be chosen between by the end-user using the pushbutton, providing greater temperature control to the end-user while helping to reduce overall heating energy consumption. LED indicators illuminate to display which mode the thermostat is operating in.

Product Wiring

1. **IMPORTANT:** ensure all electrical connections are isolated before commencing any work on the unit.
2. Power to the thermostat is provided via the Live and Neutral input terminals labelled “L” and “N” (230V AC, 50Hz). This supply should be suitably fused (recommended: 1A slow blow).
3. **NOTE:** This thermostat **MUST** be earthed using the earth terminal provided.
4. A voltage-free changeover relay output capable of switching loads of up to 10A, 250V AC (resistive) is provided by the thermostat.
5. The Common “COM” terminal is connected to the Normally Open “N/O” terminal when the sensed room temperature is above the “Setpoint” temperature.
6. Conversely, it is connected to the Normally Closed “N/C” terminal when the room temperature is sensed to be below the “Setpoint”.
7. The temperature sensor is factory fitted to all models with the exception of the Remote Sensor versions. The 2-core screened cable connection should be made to the “Temp. Sensor” terminals in this case.

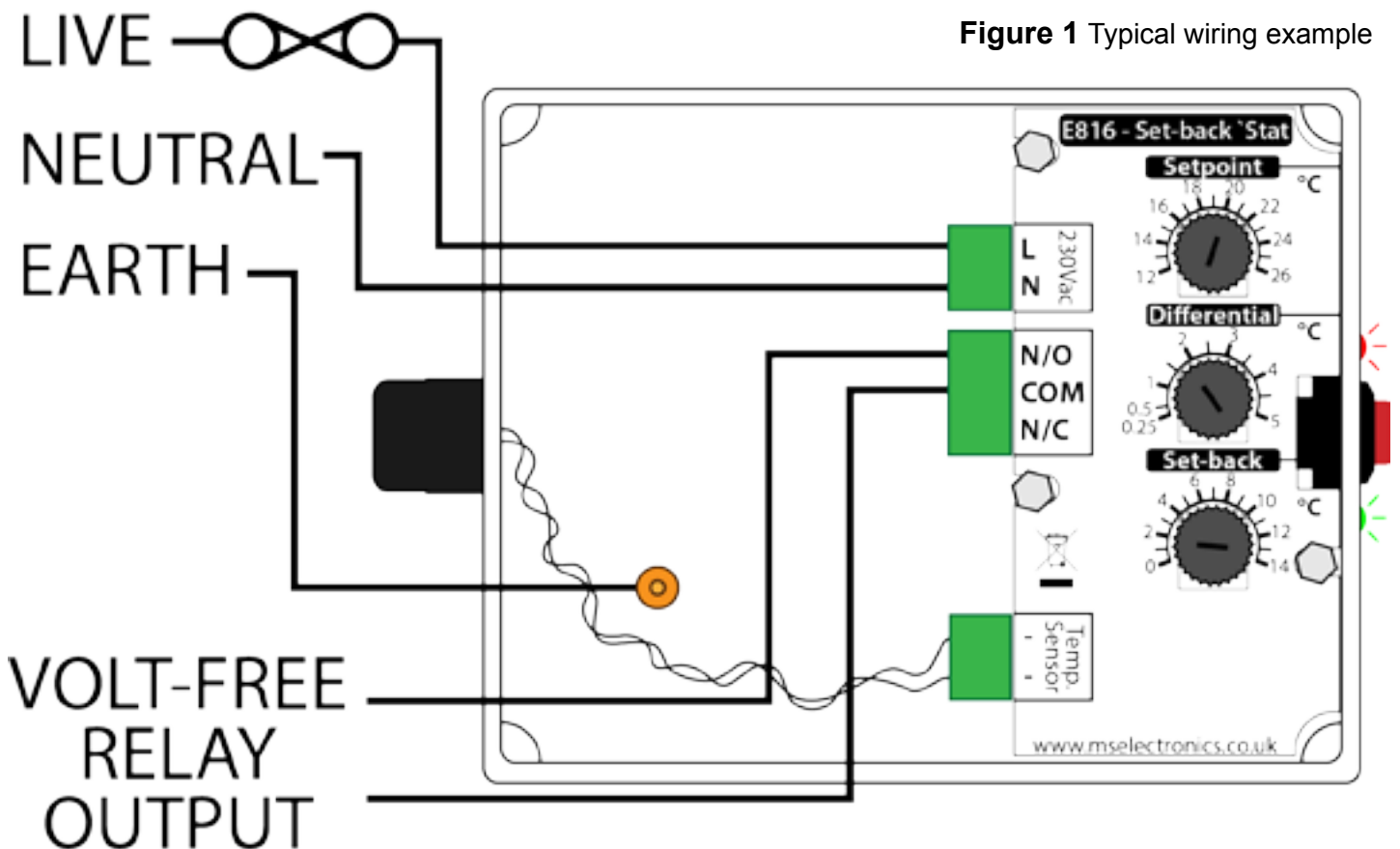

Figure 1 Typical wiring example

Installation

1. **IMPORTANT:** ensure all electrical connections are isolated before commencing any work on the unit.
2. Unscrew the 4 security screws using M.S. Electronics tamperproof screwdriver MSD-152 to remove the front cover.
3. Mount the unit securely using any suitable fixing in conjunction with the mounting holes provided in the unit. For optimal results, position the temperature sensor out of direct sunlight and well away from any heating/cooling sources.
4. Connect the wiring as shown in the diagram (or any suitably appropriate form) using the convenient pluggable terminal blocks provided. Make sure to choose the correct output terminals that are suitable to your application.
5. On the remote sensor version, 2-core screened cable should be used to connect the remote sensor to the thermostat. The screen should be connected to the earth terminal ONLY (do not connect the screen to anything at the remote sensor end).
6. Adjust the internal controls to suit the operational requirements (see below).
7. Replace the cover securely using the 4 security screws

Operation

1. **IMPORTANT:** ensure all electrical connections are isolated before commencing any work on the unit.
2. Adjust the “Setpoint” dial to the temperature the room is to be regulated at (typically 20°C).
3. Set the “Differential” to the total temperature swing either side of the “Setpoint” that the room temperature is required to keep within (typically 1°C).
4. Adjust the “Set-Back” to the temperature below the HIGH “Setpoint” to obtain the desired temperature in LOW mode.
5. Example of a standard set-up:
 - HIGH mode (**RED** LED)
 - “Setpoint” set to 20°C and “Differential” set to 1°C
 - The unit will maintain the temperature between 19.5°C and 20.5°C
 - LOW mode (**GREEN** LED)
 - “Setpoint” set to 20°C, “Differential” set to 1°C and “Set-Back” set to 5 °C
 - The unit will maintain the temperature between 14.5°C and 15.5°C

Technical Specification	
Power supply:	220V - 240V AC 50Hz (live/neutral/earth) 22V - 26V AC or DC [/24V variant only]
Output switch rating:	10A, 250V AC 50Hz (resistive)
Output switch type:	Changeover relay (volt-free)
Temperature control:	[high setpoint]: +12°C to +26°C [low setpoint]: 0°C to 14°C below the high setpoint
Temperature differential:	0.25°C to 5°C
Sensor drift:	0.15°C over 5 years
Guarantee:	5 Years
Weight:	0.31Kg
Dimensions mm:	120mm x 95mm x 35mm

Product Accessories	
MSD-152	M.S. Electronics tamperproof screwdriver
MSD-150	Air temperature sensor (sensor only)
MSD-224	Air temperature sensor (internal, boxed)
MSD-370	Air temperature sensor (internal, faceplate)

Technical Support

For further help or information on this and the other products in the ms electronics range visit www.mselectronics.co.uk or call 0333 666 1176.

Alternatively, email techsupport@mselectronics.co.uk
Additional copies of this product guide can be downloaded from our website.

Product Warranty

M.S. Electronics guarantees all their products against manufacturing defects for 5 years from the purchase date. If your product is found to be faulty, M.S. Electronics will, at their discretion, repair or replace the product free of charge.

Note

Any modification or damage to the outer casing of the thermostat, as well as any damage to the product due to abuse or incorrect wiring may invalidate the guarantee.



e: info@mselectronics.co.uk
t: 0333 666 1176 f: 0333 666 1436



mselectronics.co.uk

M.S. Electronics reserves the right to alter or change this specification without prior notice.