

Product Guide

Soft Start Controller with Remote Switch Input

An abstract graphic consisting of numerous thin, light blue lines that flow and curve across the page, creating a sense of motion and energy. The lines are most dense in the middle and right sections, with some lines extending towards the left edge.

today, tomorrow and in the future

mselectronics.co.uk

Product Overview

The SST6-RSW Soft Start Controller is a fully weatherproof (IP65-rated) solution for controlling electric heaters (such as quartz halogen). It prolongs the life of the heater through the use of soft-start and soft-stop technology, augmenting the function of a familiar on/off switch.

The SST6-RSW features low voltage safety isolated terminals for the connection of a latching switch (such as a conventional light switch, not supplied) with which to operate the unit. When switched on, power is gradually applied to the heater over 3 seconds, reducing stress to the element and electrical supply. When the switch is returned to the off position, the heater is turned off in a similar manner.

Product Wiring

1. A suitable means to isolate the electrical supply to the unit must be provided.
2. The power terminals are suitable for use with up to 4mm² conductors. Use round cable of an appropriate rating for the loads to be connected, noting that the **SUPPLY** terminals carry the total load current, as well as powering the control circuitry. Ensure all connections are tight, and free of stray strands.
3. The power cable glands are suitable for outer diameters of 7 to 13mm. If more than two load cables are to be connected, use an appropriate junction box. **Do not** pass more than one cable through one gland.
4. One gland is supplied fitted with a blanking plug. If all glands are to be used, remove the plug, otherwise it **must** be left in place to retain the IP rating. It may be moved to another gland if more convenient.
5. Remote input terminals are suitable for up to 2.5mm² solid or 1.5mm² stranded conductors. Low voltage cable may be used, but must have a round profile (not oval or figure-8) of 4 to 9mm outer diameter.
6. When retightening the gland nuts onto the cable, ensure that the rubber sealing ring is correctly in place and that the gland firmly grips the **outer** sheath.

Installation



All electrical installation and maintenance must be carried out by qualified personnel in accordance with the current edition of the IET Wiring Regulations (BS7671).

1. Loosen the four screws to remove the front cover.
2. Mount the unit securely to a vertical surface (away from direct radiation from the heater, and preferably also from direct sunlight) using appropriate hardware with the four mounting holes indicated in Figure 1.
IMPORTANT: The cable glands must face downwards. Drilling any additional holes in the box will harm the integrity of the watertight seal and invalidate the warranty.
3. Make connections as detailed in Figure 1 and the *Product Wiring* section.
4. Reattach the cover securely, alternating between screws in opposite corners to create an even seal.

Operation

1. To switch on the heater, turn on the remote switch (closing the terminals). The heater will be gradually powered up over a 3-second soft start.
2. To switch off the heater, turn off the remote switch (opening the terminals). The unit will gradually turn off the heater over 3 seconds, and then return to the standby state.

No setup or adjustment of internal controls is necessary for operation of the unit.



If the front cover is to be removed, first ensure the electrical supply to the unit is isolated.

Additional operating guidelines:

1. If the switch is operated again just after the heater has been switched off, there may be a slight delay before it begins to power up. This is normal and helps to protect the unit from overheating.
2. If the unit will not trigger, it may have detected excessive use and temporarily inhibited activation as a protective measure. Wait 20 to 60 seconds before reattempting to operate the unit. If the switch is left in the 'on' state, the unit will power up the heater as soon as it is ready.

Figure 1 Typical wiring example and dimensions (in millimetres)

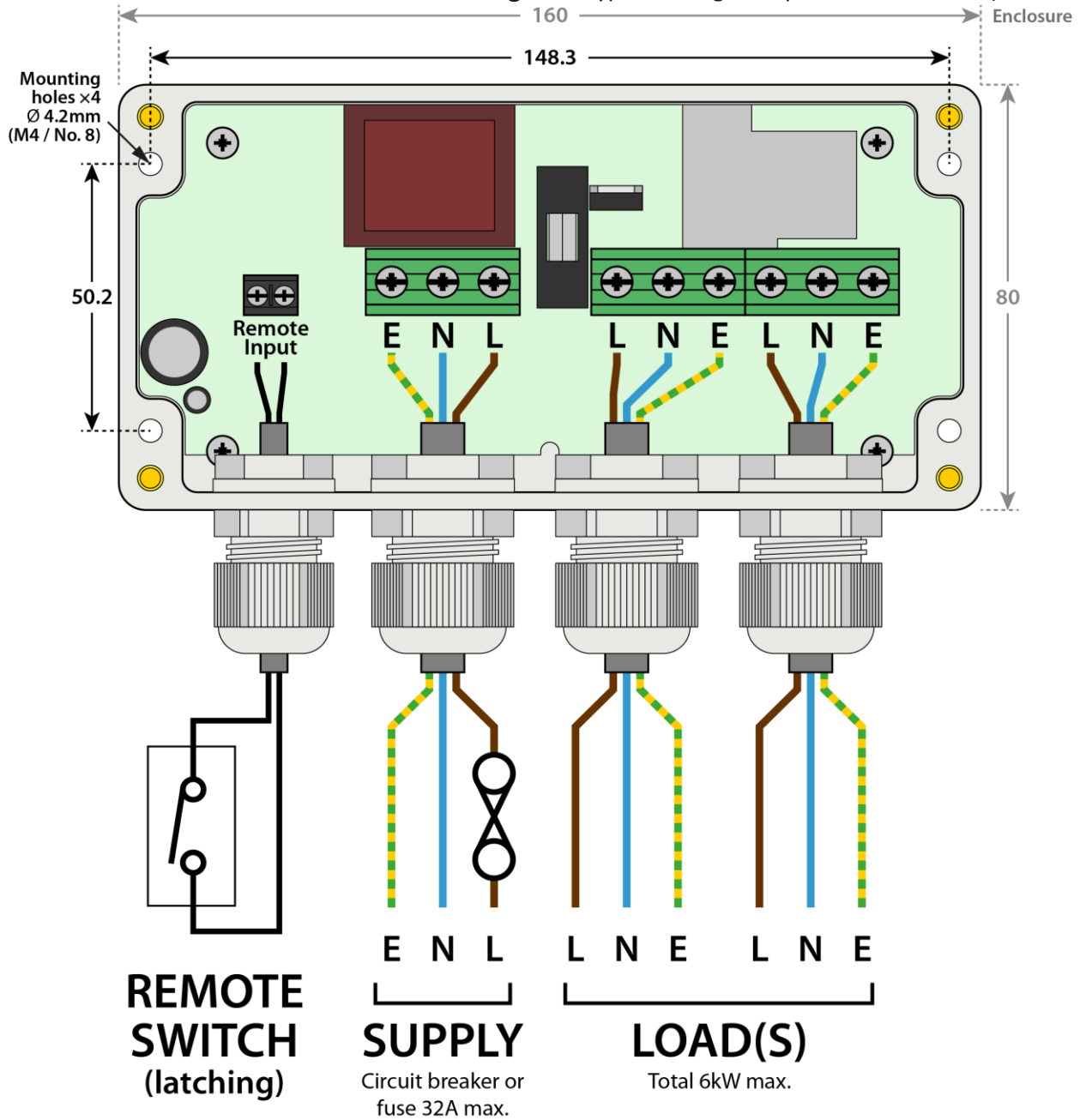

Technical Specification	
Power supply:	220V - 240V AC 50Hz (live/neutral/earth)
Load capacity:	35W - 6000W (resistive)
Power consumption (control circuit):	<1W (standby), 2W (active)
Internal fuse (for control circuit):	250V F1A (fast blow), 5 x 20mm glass cartridge
Output type:	Triac soft-start/stop with relay bypass (switched L, common N)
Remote input type:	SELV, latching (closed = 'ON')
Cable gland capacity:	Supply/Load: M20, for 7-13mm dia. round cable Remote Input: M16, for 4-9mm dia. round cable
Operating temperature:	-10°C to +40°C
Protection rating:	IP65
Guarantee:	3 Years
Weight:	450g
Dimensions (excluding projections):	160mm x 80mm x 55mm

IMPORTANT INSTALLATION NOTICE

The installation of this product should be carried out in accordance with the latest IEE wiring regulations and all wiring completed by a qualified electrician.

Technical Support

For further help or information on this and the other products in the MS Electronics range visit www.mselectronics.co.uk or call 0333 666 1176.

Alternatively, email techsupport@mselectronics.co.uk

Additional copies of this product guide can be downloaded from our website.

Product Warranty

MS Electronics guarantees all their products against manufacturing defects for 3 years from the purchase date. If your product is found to be faulty, MS Electronics will, at their discretion, repair or replace the product free of charge.

Note

Any modification or damage to the outer casing of the product, as well as any damage to the product due to abuse or incorrect wiring may invalidate the guarantee.

e: info@mselectronics.co.uk

t: 0333 666 1176/01708 448566



MS Electronics reserves the right to alter or change this specification without prior notice.