

Product Guide

Pull Cord Time Delay Switch

2-wire version

today, tomorrow and in the future

mselectronics.co.uk

Issue 3.0

Product Overview

The PCTDS2 Pull Cord Time Delay Switch provides timed switching for lighting, heating, air conditioning and ventilation equipment. For locations suiting pull cord control, the unit offers easy activation of the connected load whilst saving energy by switching it off automatically when not required (after an adjustable period). At any time, the activation period may be extended with a further brief pull of the cord, or cancelled by holding momentarily. The unit is available with different time delay ranges (see *Technical Specification*).

The unit is simple to install and fits a standard single-gang UK pattress or back box (28mm min. depth). Ideal applications include small booths or rooms, workshops, entrance halls, staircases, toilets, store cupboards, hired sports courts and rooms plus many more.

Figure 1 PCTDS2



Figure 2 Typical wiring example and dimensions (in millimetres)

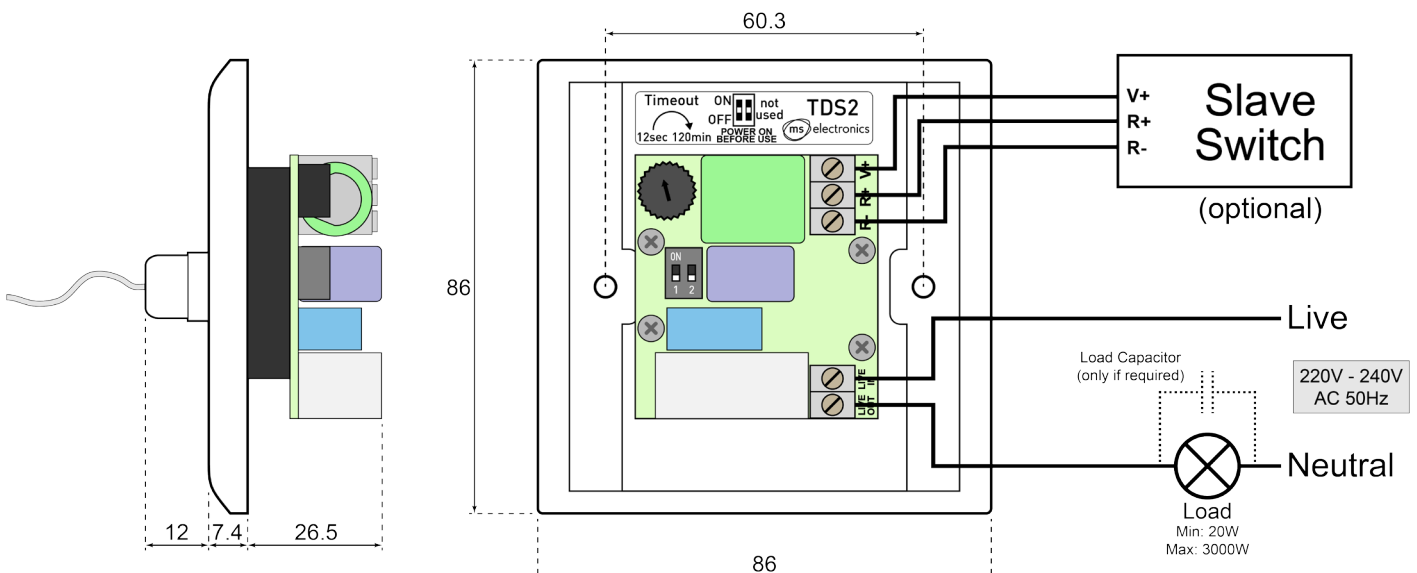



Electrical Requirements

Before attempting to install the unit, ensure that the intended load and wiring arrangement comply with the following requirements. Figure 2 shows a typical wiring example.

- **2-wire (live/load) connection:** The unit connects 'inline' with the load, and is therefore suited to replacing an existing standard light switch (or similar) with no permanent mains neutral conductor available at the switch location.
- **Minimum load:** This 2-wire model requires a minimum load of **20W (per switch unit)** in order to function correctly. If this is not met, or if faults occur in use (such as the load not switching off), a load capacitor (MS Electronics product code **CAP68**) may be required.
Also available: PCTDS3 (3-wire version) – No minimum load; volt-free relay output (can be used with an independently-powered load or as a contact closure). Requires a permanent mains live/neutral connection.
- **Maximum load:** The maximum load rating is **16A (4000W)**, however for high inrush loads (such as most types of lighting), a lower limit applies: see *Technical Specification*.

Installation

 All electrical installation and maintenance must be carried out by a competent person. If in doubt, consult a qualified electrician. Any new wiring must be carried out by qualified personnel in accordance with the current edition of the IET Wiring Regulations (BS7671).

 Ensure the electrical supply is isolated before making any connections or adjustments.

1. Prepare a single-gang pattress or back box as necessary.
2. The unit contains a battery, which must be switched on prior to use. Using e.g. a small screwdriver, move **Switch 1** to the 'ON' position as indicated on the accompanying label.
3. Rotate the **Timeout** thumbwheel (referring to the accompanying label) to set the period of time for which the load should remain switched on after the pull cord is operated.
4. Connect the wiring as shown in Figure 2 (or in any suitably appropriate form).
 - **Supply/load connections (LIVE IN, LIVE OUT):** Use mains cable having a current rating appropriate to the load.
 - **Slave switch connections (V+, R+, R-) if required:** Low-current cable may be used but **must be rated for mains voltages**. See *Using Multiple Switches* for wiring details and slave switch options.
5. Fix the unit into position with the two screws and caps supplied.

Additional Guidelines

- **Switch 2** is not used on this model and should not be adjusted.
- If the unit will be disconnected from the mains supply for an extended period, return **Switch 1** to the 'OFF' position until it is next required.
- The screw caps may be removed at a later date with the aid of an adhesive putty such as Blu-Tack.

Operation

The diagram below illustrates the sequence of operation for the unit.

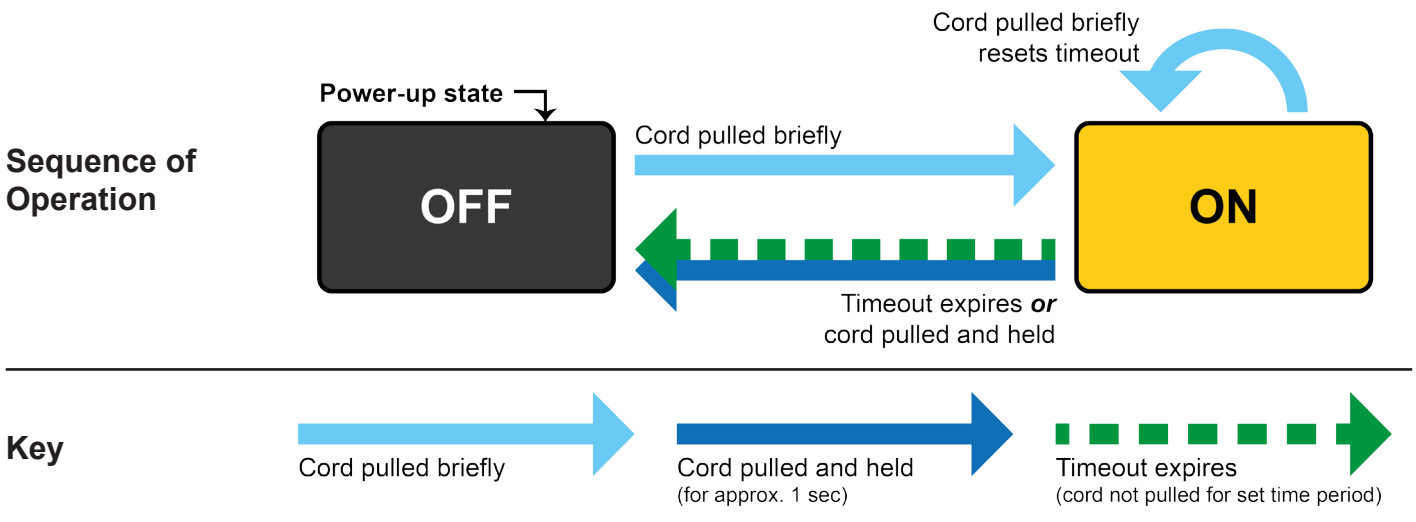

Using Multiple Switches

To allow the connected load to be controlled from more than one location, multiple switches may be connected, either in parallel, or using lower cost slave switches connected to a single master switch.

⚠ The following wiring examples are intended only as recommendations. Proper wiring practice must be observed with relevance to the particular installation.

Example 1: Parallel Wiring

Figure 3 illustrates a typical wiring arrangement using two PCTDS2 units; Figure 4 represents the same configuration as applied to a typical ceiling rose lighting circuit. This method can typically reuse pre-existing wiring from a 2-way switching installation where 3-core cable has been run between the switch locations, noting that only two of the cores are needed.

Each unit operates its own timing cycle, but the load is shared. When either unit (or both) is activated by its respective pull cord, the load will switch on. Once *both* units have timed out, the load will switch off. Note that when pulling and holding the cord to cancel the timeout, the load will remain powered if the other unit is still in the 'ON' state. For full control from any switch location, see *Example 2*.

The total minimum load requirement increases in line with the number of units sharing the same load, e.g. for two units, $2 \times 20W = 40W$. If necessary, connect a load capacitor – see *Electrical Requirements*.

Figure 3 Typical wiring schematic for two units

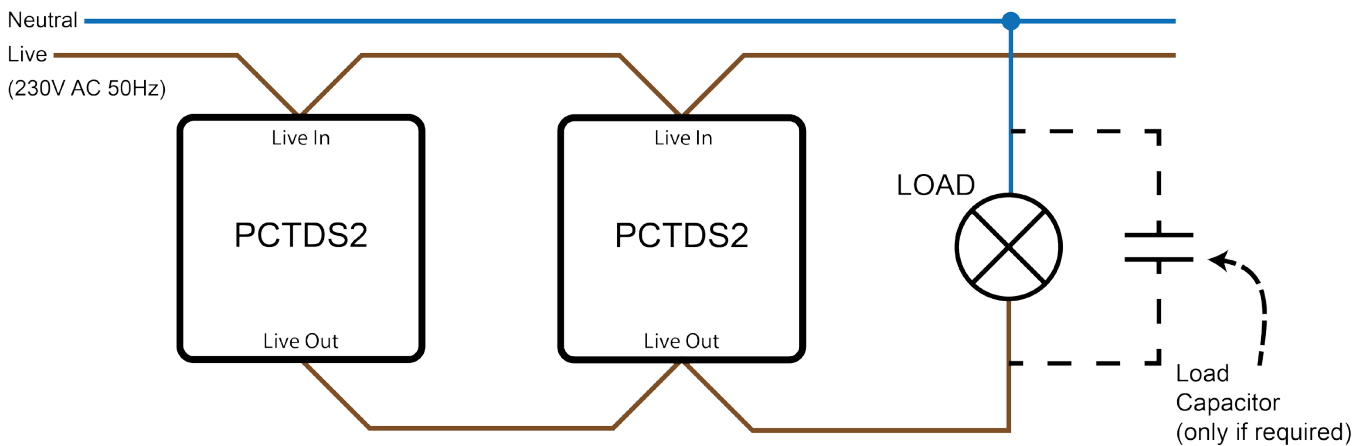
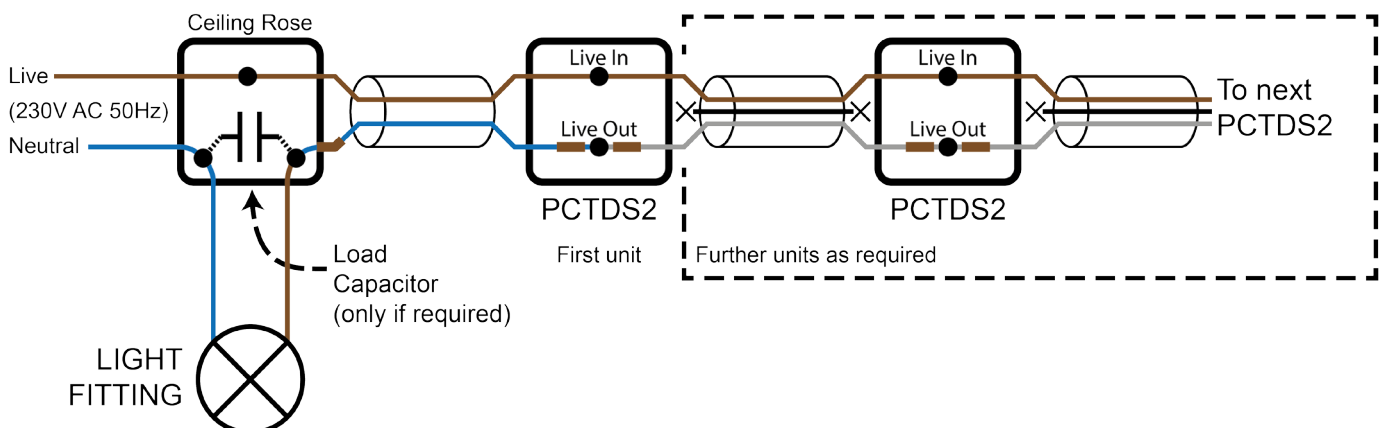

Figure 4 Typical ceiling rose plan



Example 2: Master with Slave Units

The remote interface feature offers the option of lower cost 2-way or multi-way switching by connecting up to five slave switches to a single PCTDS2 master unit. Unlike parallel wiring (*Example 1*), this method retains full control from any switch location, and does not increase the minimum load requirement. The master unit controls the timing cycle and switches the load, and any of the slave switches will function identically to that on the master unit.

Each slave switch may be either a PCTDS-S slave unit (which provides an identical pull cord) or an ordinary normally-open mechanical switch (such as a pushbutton or retractive rocker). Referring to the steps under *Installation*, connect as follows.

- PCTDS-S and other switches:** Use 2-core mains-rated cable to connect to the **R+** and **R-** terminals only (polarity does not matter); do not use the **V+** terminal. Figure 5 illustrates a typical wiring example using two PCTDS-S slave units; Figure 6 represents the same configuration as applied to a typical ceiling rose lighting circuit.

 The slave switch connections are referenced to the mains supply of the unit, and are therefore *not* safe to touch when the unit is powered. All switches and cables must be rated for mains voltages.

Figure 5 Typical wiring schematic using two PCTDS-S slave units

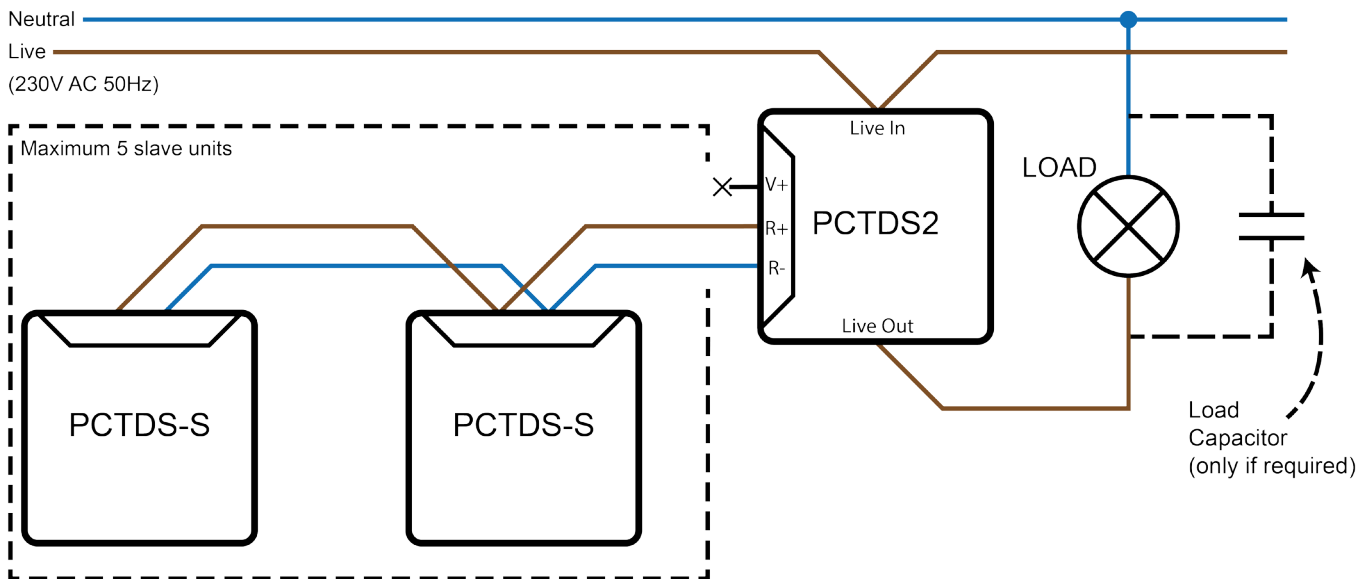
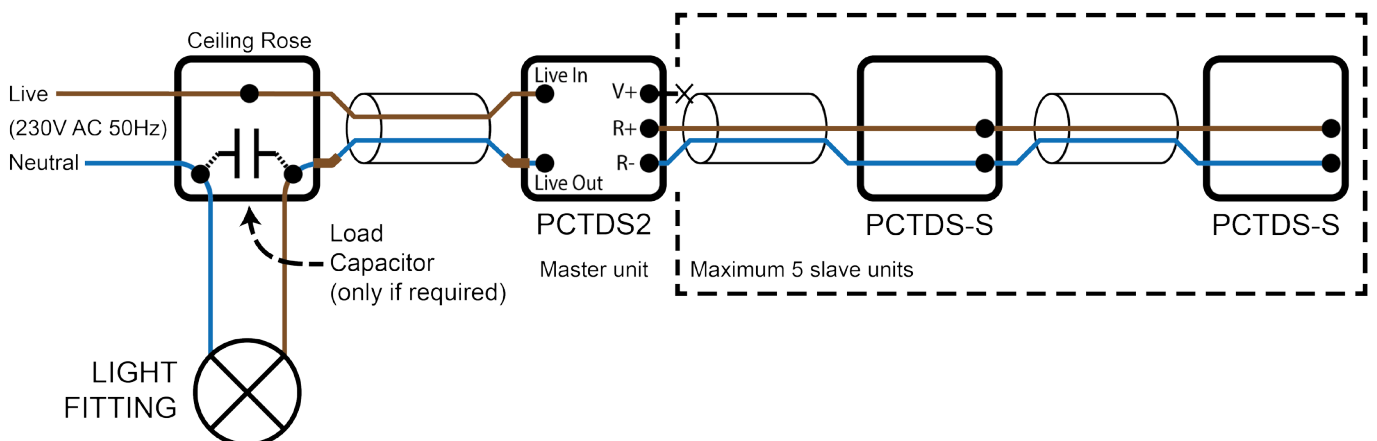

Figure 6 Typical ceiling rose plan using two PCTDS-S slave units



Fault Finding



Ensure the electrical supply to the unit is isolated before making any adjustments.

Load will not switch on

a) Unit is not powered correctly (or load circuit is faulty)

- Ensure the unit is correctly connected to an active mains supply and load circuit.
- Ensure the internal battery is switched on using **Switch 1** on the back of the unit.
- Check that the load works on its own by bypassing the time delay switch.

b) Internal battery is low

- Leave the unit powered for at least 3 hours to allow the battery to charge before retrying.

Load switches on, but does not switch off (or lighting load flickers)

- Ensure the set period has elapsed since the pull cord was last operated.
- Ensure the minimum load requirement has been met: see *Electrical Requirements*.

| Technical Specification | |
|-------------------------|---|
| Power supply | 220V - 240V AC 50Hz (in-the-line) |
| Output switch rating | 16A, 250V AC (resistive) |
| Minimum load | 20W |
| Maximum lighting load | Incandescent: 12A (3000W) Fluorescent: 10A (2500W) Compact Fluorescent: 10A (2500W) |
| Time delay selection | 3 seconds to 30 minutes or 6 seconds to 60 minutes or 12 seconds to 120 minutes |
| Mounting hardware | 28mm (min.) single-gang UK pattress box |
| Operating temperature | -10°C to +40°C |
| Guarantee | 2 Years |
| Weight | 106g |
| Dimensions | 86mm x 86mm x 47mm |

Technical Support

For further help or information on this and other products in the MS Electronics range visit www.mselectronics.co.uk or call 0333 666 1176.

Alternatively, email techsupport@mselectronics.co.uk
Additional copies of this product guide can be downloaded from our website.

Product Warranty

MS Electronics guarantees all their products against manufacturing defects for 2 years from the purchase date. If your product is found to be faulty, MS Electronics will, at their discretion, repair or replace the product free of charge.

Note

Any modification or damage to the product including damage due to abuse or incorrect wiring may invalidate the guarantee.



e: info@mselectronics.co.uk
t: 0333 666 1176 f: 0333 666 1436



mselectronics.co.uk

Follow us on twitter: [@mselec](https://twitter.com/mselec)

MS Electronics reserves the right to change this specification without prior notice.