

Product Guide

IP65 Rated Time Delay Switch
3-wire version

today, tomorrow and in the future

mselectronics.co.uk

Issue 3.0

Product Overview

The IPTDS3 IP65 Rated Time Delay Switch provides timed switching for lighting, heating, air conditioning and ventilation equipment in a fully weatherproof, IP65-rated enclosure. The unit features an illuminated pushbutton (to aid location of the unit in the dark), offering easy activation of the connected load whilst saving energy by switching it off automatically when not required (after an adjustable period). At any time, the activation period may be extended with a further brief press, or cancelled by holding momentarily. The unit is available with different time delay ranges (see *Technical Specification*).

Ideal applications include pubs and restaurants, patios and beer gardens, smoking shelters, churches, garages and workshops, warehouses and agricultural buildings plus many more.

Figure 1 IPTDS3



Figure 2 Typical wiring example and dimensions (in millimetres)

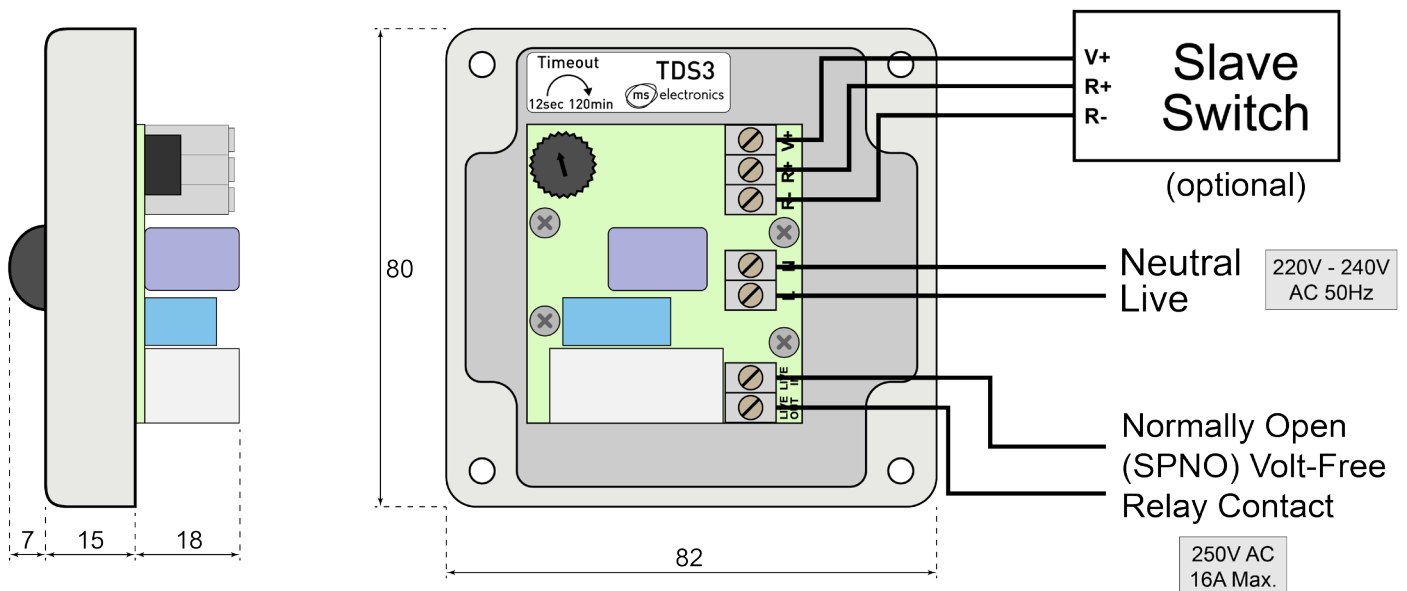



Electrical Requirements

Before attempting to install the unit, ensure that the intended load and wiring arrangement comply with the following requirements. Figure 2 shows a typical wiring example.

- **3-wire (live/neutral + volt-free switch) connection:** The unit requires a permanent live/neutral connection, and as such is *not* suitable for replacing an existing light switch with no neutral conductor at the switch location. A volt-free relay output is provided, which can be used to switch a load on the same mains supply (by connecting across from **L** to **LIVE IN**, making **LIVE OUT** a switched live), or to provide a contact closure to a separate load or control signal. There is no minimum load requirement.
Also available: IPTDS2 (2-wire version) – Suitable for ‘inline’ connection with the load to be switched (no neutral required), such as to replace a standard light switch. A minimum load of **20W (per switch unit)** applies; a load capacitor is required for smaller loads.
- **Maximum load:** The maximum load rating is **16A (4000W)**, however for high inrush loads (such as most types of lighting), a lower limit applies: see *Technical Specification*.
- **Cable entry:** The pre-fitted cable gland is suitable for *one* round cable with an outer diameter of **5-13mm**. If necessary, use an appropriate junction box and connect to the unit using cable with enough cores for all connections. Drilling holes for additional cables may degrade the weatherproof integrity of the enclosure and invalidate your warranty.

Installation

 All electrical installation and maintenance must be carried out by a competent person. If in doubt, consult a qualified electrician. Any new wiring must be carried out by qualified personnel in accordance with the current edition of the IET Wiring Regulations (BS7671).

 Ensure the electrical supply is isolated before making any connections or adjustments.

1. Mount the rear part of the enclosure securely to a vertical surface using the integral mounting holes and dimensions shown in Figure 3 (overleaf).
Important: The unit *must* be mounted with the cable gland facing downwards.
2. Rotate the **Timeout** thumbwheel (referring to the accompanying label) to set the period of time for which the load should remain switched on after the pushbutton is pressed.
3. Remove the cable gland nut and feed onto the cable end. If using cable larger than 7.5mm in diameter, withdraw the rubber insert from the gland, separate the two parts and reinsert just the outer ring. The other part may be discarded.
4. Pass the cable through the gland into the enclosure. Connect the wiring as shown in Figure 2 (or in any suitably appropriate form), using mains cable having a current rating appropriate to the load.
5. Reassemble the unit securely, alternating between screws in opposite corners to create an even seal.
6. Tighten the cable gland nut securely, ensuring that the rubber sealing ring grips only the outer cable sheath; the stripped portion must be fully inside the enclosure.

Figure 3 Enclosure dimensions (in millimetres)

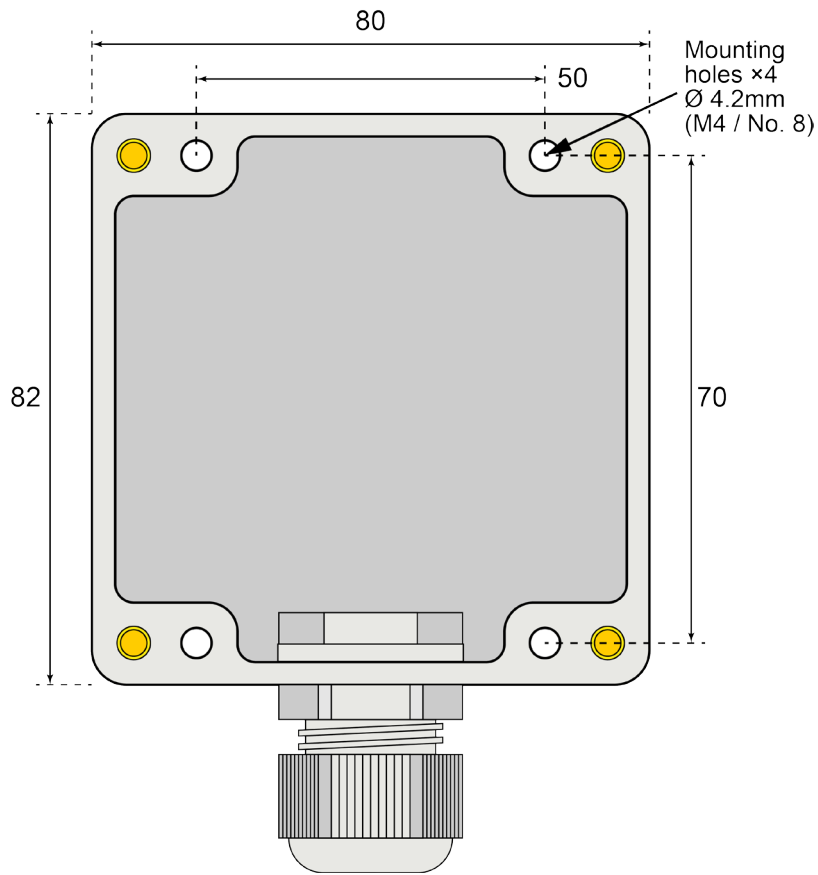

Operation

The diagram below illustrates the sequence of operation for the unit.

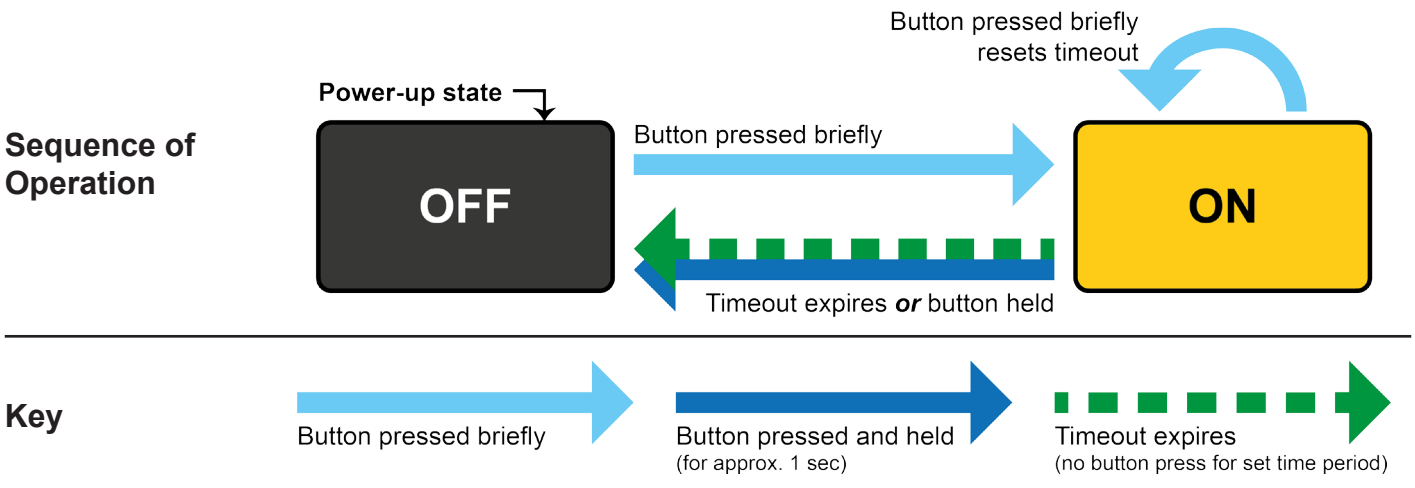

Operation Notes

- In the 'OFF' state, the pushbutton LED is lit to facilitate location of the unit in the dark.

Using Multiple Switches

To allow the connected load to be controlled from more than one location, multiple switches may be connected, either in parallel, or using lower cost slave switches connected to a single master switch.

 The following wiring examples are intended only as recommendations. Proper wiring practice must be observed with relevance to the particular installation.

Example 1: Parallel Wiring

Figure 4 illustrates a typical wiring arrangement using two IPTDS3 units; Figure 5 represents the same configuration as applied to a typical ceiling rose lighting circuit. This method can typically reuse pre-existing wiring from a 2-way switching installation where 3-core cable has been run between the switch locations.

Each unit operates its own timing cycle, but the load is shared. When either unit (or both) is activated by its respective pushbutton, the load will switch on. Once *both* units have timed out, the load will switch off. Note that when holding the button to cancel the timeout, the load will remain powered if the other unit is still in the 'ON' state. For full control from any switch location, see *Example 2*.

Figure 3 Typical wiring schematic for two units

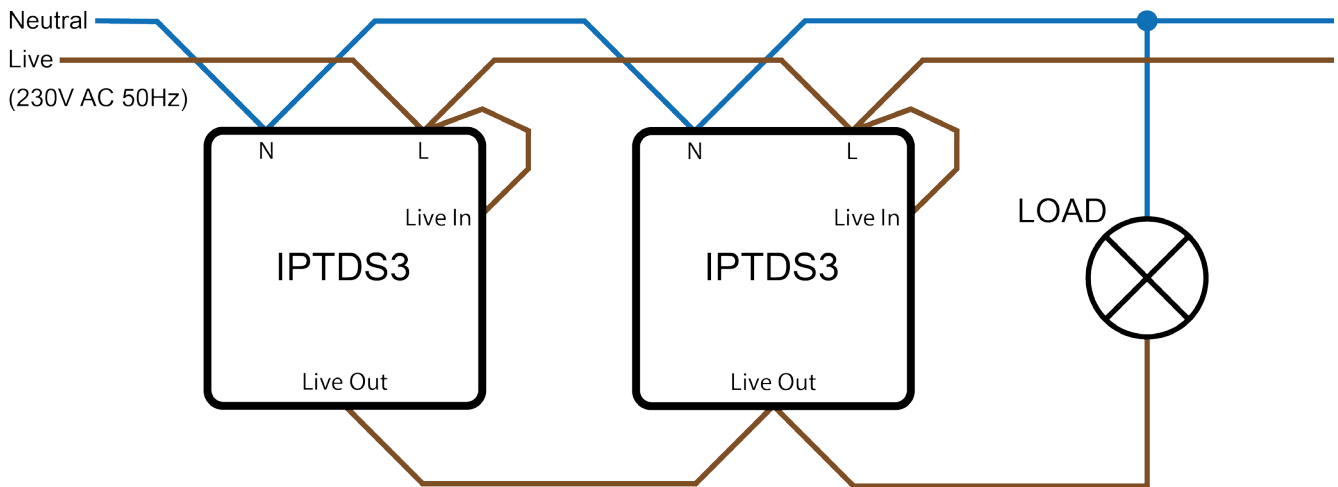
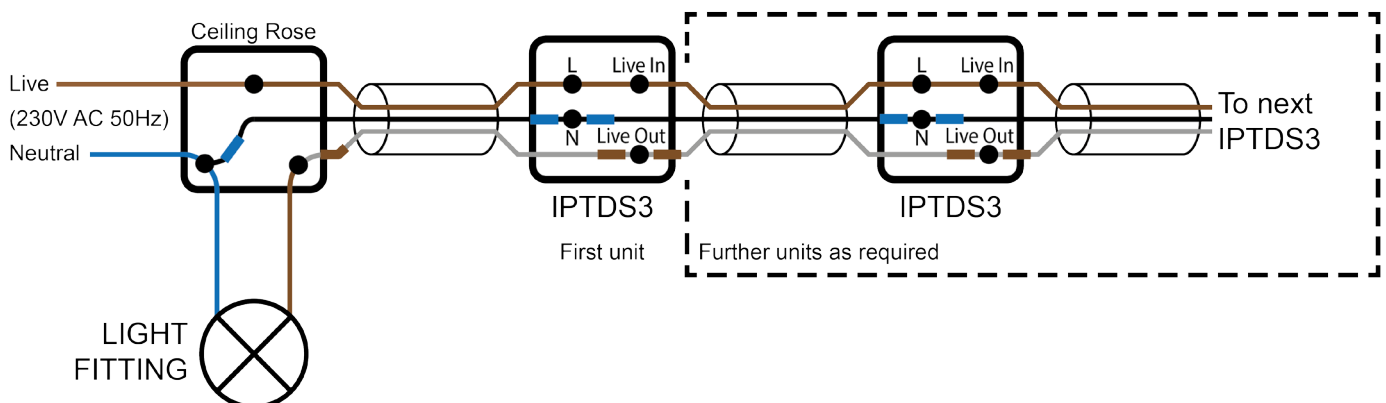

Figure 4 Typical ceiling rose plan



Example 2: Master with Slave Units

The remote interface feature offers the option of lower cost 2-way or multi-way switching by connecting up to five slave switches to a single IPTDS3 master unit. Unlike parallel wiring (*Example 1*), this method retains full control from any switch location, and does not increase the minimum load requirement. The master unit controls the timing cycle and switches the load, and any of the slave switches will function identically to that on the master unit.

Each slave switch may be either an IPTDS-S slave unit (which provides a non-illuminated IP65-rated pushbutton) or an ordinary normally-open mechanical switch (such as a pushbutton or retractive rocker). Referring to the steps under *Installation*, connect as follows.

- **IPTDS-S and other switches:** Use 2-core mains-rated cable to connect to the **R+** and **R-** terminals only (polarity does not matter); do not use the **V+** terminal. Figure 5 illustrates a typical wiring example using two IPTDS-S slave units; Figure 6 represents the same configuration as applied to a typical ceiling rose lighting circuit.

 The slave switch connections are referenced to the mains supply of the unit, and are therefore *not* safe to touch when the unit is powered. All switches and cables must be rated for mains voltages.

Figure 5 Typical wiring schematic using two IPTDS-S slave units

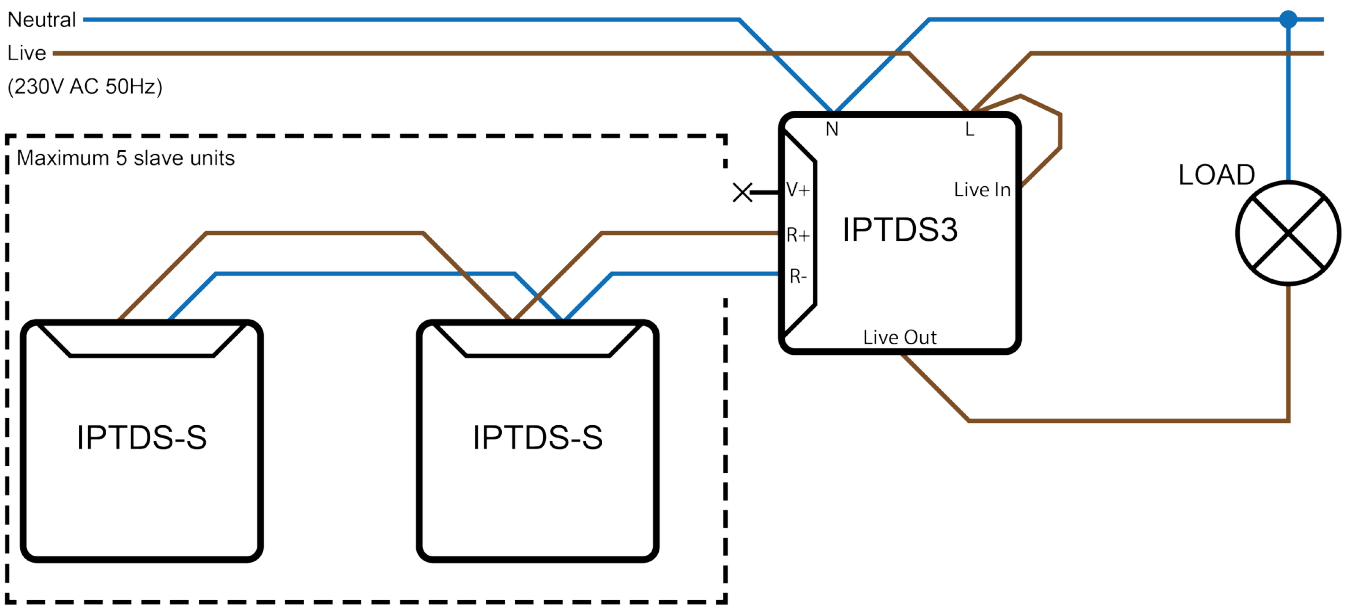
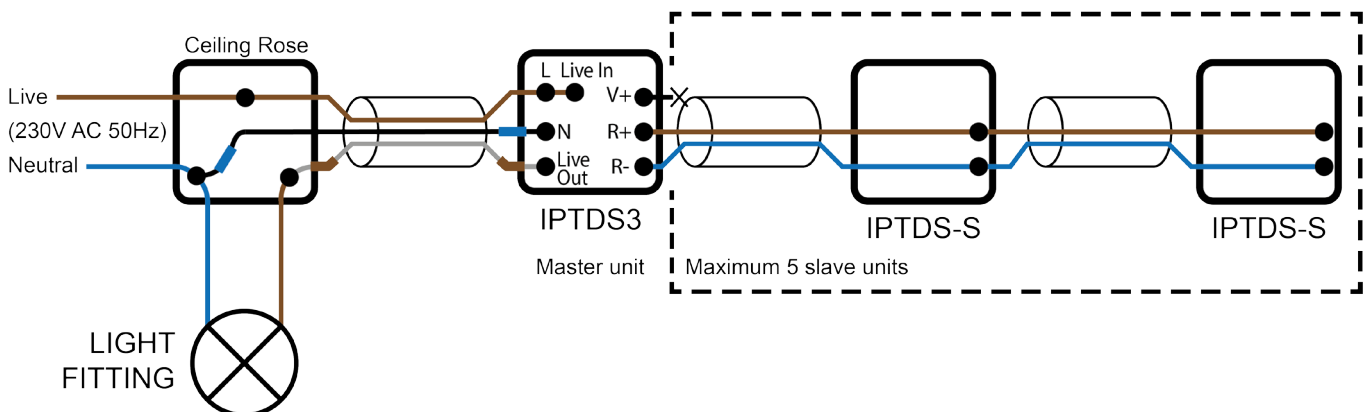

Figure 6 Typical ceiling rose plan using two IPTDS-S slave units



Fault Finding



Ensure the electrical supply to the unit is isolated before making any adjustments.

Load will not switch on

a) Unit is not powered

- Ensure the unit is correctly connected to an active mains supply.

b) Load is not connected correctly

- Ensure the load is connected appropriately. The relay output is volt-free so must be connected suitably to a supply in order to power a load.
- Check that the load works on its own by bypassing the time delay switch.

Load switches on, but does not switch off

- Ensure the set period has elapsed since the pushbutton was last pressed.

Technical Specification	
Power supply	220V - 240V AC 50Hz (live/neutral)
Output switch type	Volt-free SPST (normally open) relay
Output switch rating	16A, 250V AC (resistive)
Maximum lighting load	Incandescent: 12A (3000W) Fluorescent: 10A (2500W) Compact Fluorescent: 10A (2500W)
Time delay selection	3 seconds to 30 minutes or 6 seconds to 60 minutes or 12 seconds to 120 minutes
Cable gland capacity	5 to 13mm dia. round cable (Remove reducer insert for >7.5mm)
Operating temperature	-10°C to +40°C
Guarantee	5 Years
Ingress protection	IP65
Weight	165g
Dimensions	82mm x 80mm x 55mm

Technical Support

For further help or information on this and other products in the MS Electronics range visit www.mselectronics.co.uk or call 0333 666 1176.

Alternatively, email techsupport@mselectronics.co.uk
Additional copies of this product guide can be downloaded from our website.

Product Warranty

MS Electronics guarantees all their products against manufacturing defects for 5 years from the purchase date. If your product is found to be faulty, MS Electronics will, at their discretion, repair or replace the product free of charge.

Note

Any modification or damage to the product including damage due to abuse or incorrect wiring may invalidate the guarantee.



e: info@mselectronics.co.uk
t: 0333 666 1176 f: 0333 666 1436



mselectronics.co.uk

Follow us on twitter: [@mselec](https://twitter.com/mselec)

MS Electronics reserves the right to change this specification without prior notice.