

Product Guide

IP65 Rated Thermostat

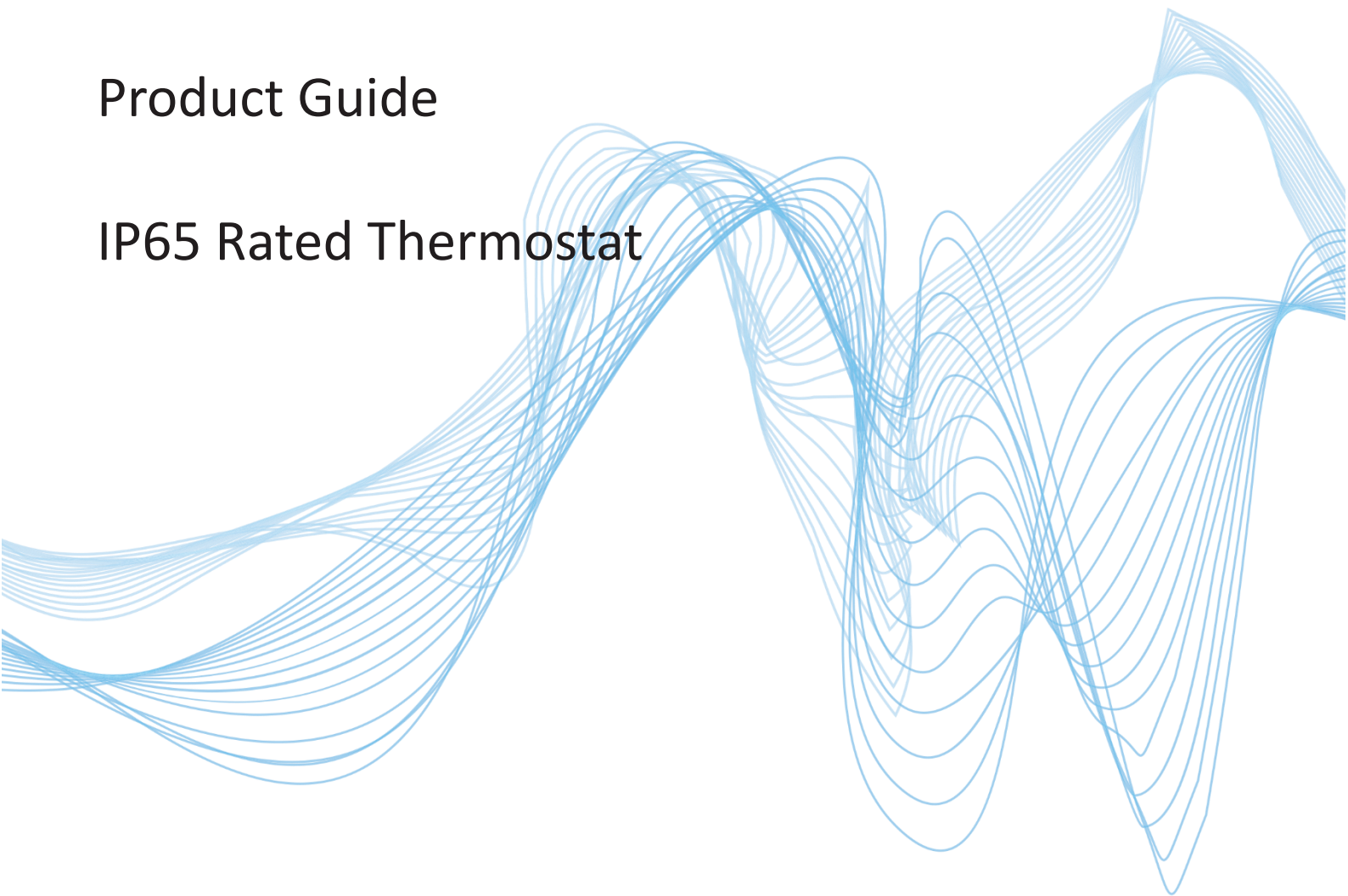

today, tomorrow and in the future

mselectronics.co.uk

Product Overview

The IP65T/F utilises an IP65 rated polycarbonate enclosure with an embedded high accuracy temperature sensor to control heating or air conditioning. A built-in M20 cable gland maintains the IP65 rating when used with appropriate electrical cable.

The temperature setpoint is fully adjustable between -2°C and $+12^{\circ}\text{C}$ and the switching hysteresis (differential) can also be adjusted between 0.25°C and 4°C .

Product Wiring

1. **IMPORTANT:** ensure all electrical connections are isolated before commencing any work on the unit.
2. Power to the thermostat is provided via the Live and Neutral input terminals labelled "L" and "N" (230V AC, 50Hz). On the 24 volt product variant ("/24V") the same terminals are used (24V AC or DC) and are not polarity sensitive.
3. A voltage-free changeover relay output capable of switching loads of up to 10A, 250V AC (resistive) is provided by the thermostat at the "NC, COM, NO" terminals. Connect to your application given the following:
 - The Common "COM" terminal is connected to the Normally Closed "NC" terminal when the sensed temperature is above the selected temperature.
 - Conversely, the "COM" terminal is connected to the Normally Open "NO" terminal when the sensed temperature is below the selected temperature.

Figure 1 Typical wiring example

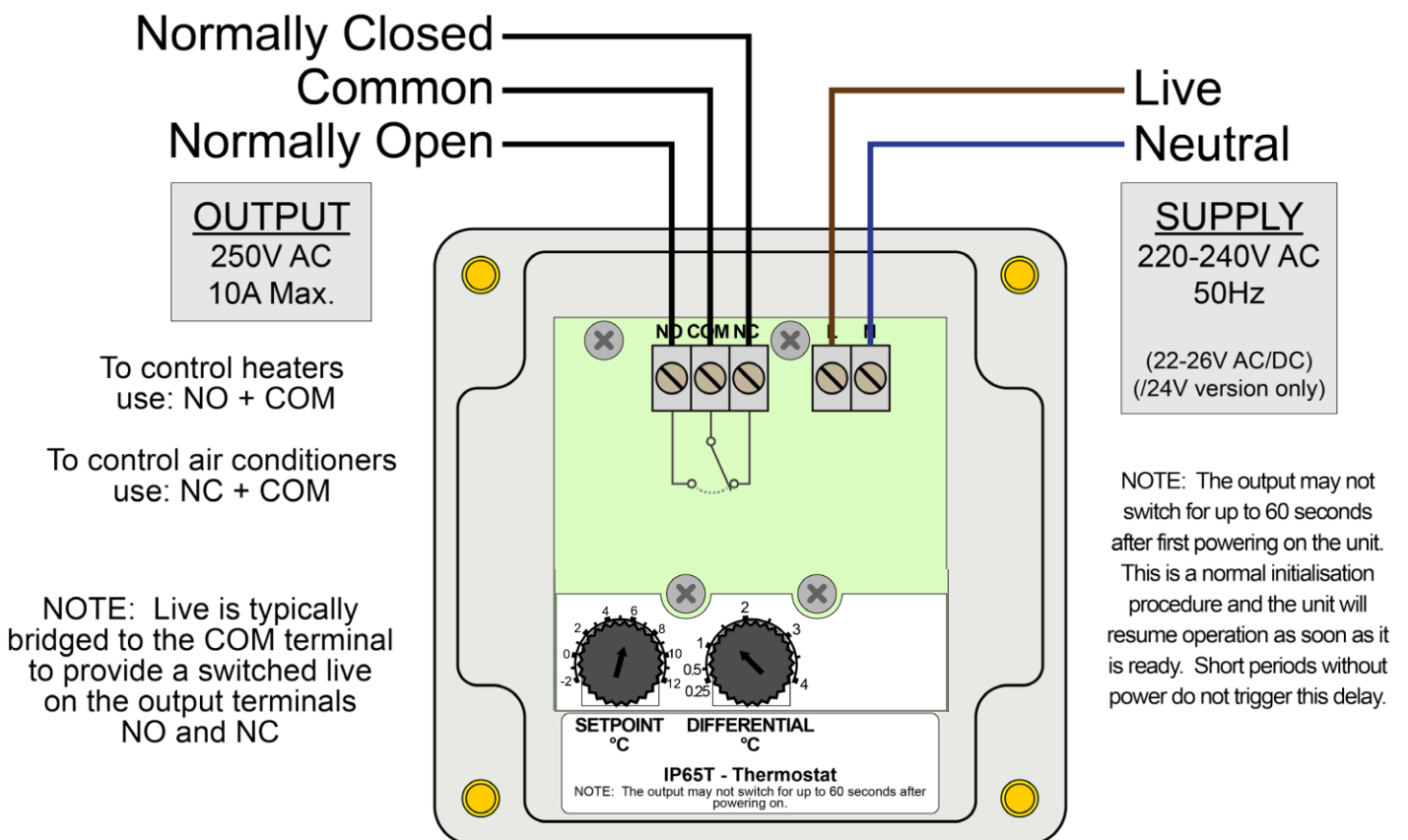

Installation

1. **IMPORTANT:** ensure all electrical connections are isolated before commencing any work on the unit.
2. Unscrew and remove the front of the enclosure which contains the electronics.
3. Mount the rear of the enclosure to the wall using the 4 pre-existing screw points. DO NOT drill through the back of the enclosure as this will void the product IP rating.
4. Ensure best-practices are used when choosing a location for the thermostat so that optimal thermostatic control is achieved. Do not mount near drafts, heaters, radiators, air conditioners, in direct sunlight or any other place where the sensed temperature may be unnaturally influenced. A good mounting height is typically between 1m and 2m from the floor.
5. Pass the electrical cable through the cable gland then connect as shown in Figure 1 (or any suitably appropriate form). Ensure the correct output terminals that are suitable to your application are chosen.
6. Adjust the internal thumbwheels to suit the desired operational requirements (see below).
7. Screw the front of the enclosure back on then tighten the cable gland to seal against the cable.

Operation

1. **IMPORTANT:** ensure all electrical connections are isolated before commencing any work on the unit.
2. Adjust the “Setpoint” dial to the temperature the area is to be regulated to.
3. Set the “Differential” to the total temperature swing either side of the resulting setpoint that the temperature is required to keep within (typically 1°C).
4. Example set-up:
 - Setpoint set to 4°C, Differential set to 1°C.
 - The thermostat will maintain the temperature between 3.5°C and 4.5°C.

24 Volt (/24V)

This thermostat is designed to operate from a 24 volt (AC or DC) power source (instead of the standard operating voltage of 230V AC).

Technical Specification	
Power supply:	220V - 240V AC 50Hz (live/neutral) 22V - 24V AC or DC (“/24V” variant only)
Output switch rating:	10A, 250V AC 50Hz (resistive)
Output switch type:	Changeover relay (volt-free)
Temperature control:	-2°C to +12°C
Temperature differential:	0.25°C to 4°C
Sensor accuracy:	±0.2°C
Sensor drift:	0.15°C over 5 years
Guarantee:	3 Years
Weight:	190g
Dimensions:	82mm x 80mm x 55mm

IMPORTANT INSTALLATION NOTICE

The installation of this product should be carried out in accordance with the latest IEE wiring regulations and all wiring completed by a qualified electrician.

Technical Support

For further help or information on this and the other products in the MS Electronics range visit www.mselectronics.co.uk or call 01708-448566

Alternatively, email techsupport@mselectronics.co.uk

Additional copies of this product guide can be downloaded from our website.

Product Warranty

MS Electronics guarantees all their products against manufacturing defects for 3 years from the purchase date. If your product is found to be faulty, MS Electronics will, at their discretion, repair or replace the product free of charge.

Note

Any modification or damage to the outer casing of the product, as well as any damage to the product due to abuse or incorrect wiring may invalidate the guarantee.

e: info@mselectronics.co.uk

t: 0333 666 1176/01708 448566

