

Product Guide

Robust Humidistat with semi-automatic on/off control

A decorative graphic consisting of numerous thin, light blue lines that flow and curve across the page, creating a sense of movement and depth. The lines are most concentrated in the middle and right sections, with some extending towards the left edge.

today, tomorrow and in the future

mselectronics.co.uk

Product Overview

The E914 offers a calibration-free, high quality solution to tamperproof humidity control. It utilises a high-accuracy humidity sensor in conjunction with its robust die-cast aluminium case and tamperproof screws to ensure vandal-resistant yet accurate tamperproof energy control.

The E914 regulates to a fully adjustable relative humidity set-point between 5% RH and 95% RH, combined with an adjustable relative humidity hysteresis (differential) of anything between 1% RH and 10% RH.

The E914's integrated pushbutton allows the room user to switch off the unit. Humidity control will automatically be restored after the "Off Timeout" period has elapsed. LED indicators illuminate to display the state of the humidistat (Green = ON (humidity control enabled) or Red = OFF (humidity control disabled)).

Product Wiring

1. **IMPORTANT:** ensure all electrical connections are isolated before commencing any work on the unit.
2. Power to the humidistat is provided via the Live and Neutral input terminals labelled "L" and "N" (230V AC, 50Hz). This supply should be suitably fused.
3. **NOTE:** This humidistat MUST be earthed using the earth terminal provided.
4. A voltage-free changeover relay output capable of switching loads of up to 16A, 250V AC (resistive) is provided by the humidistat. Connect to your application in an appropriate manner given the following:
 - If the sensed humidity is higher than the setpoint humidity:
The Common "COM" terminal is connected to the Normally Open "N/O" terminal.
(The Normally Closed "N/C" terminal is disconnected).
 - If the sensed humidity is lower than the setpoint humidity, or the OFF mode is selected:
The Common "COM" terminal is connected to the Normally Closed "N/C" terminal.
(The Normally Open "N/O" terminal is disconnected).

Figure 1 Typical wiring example

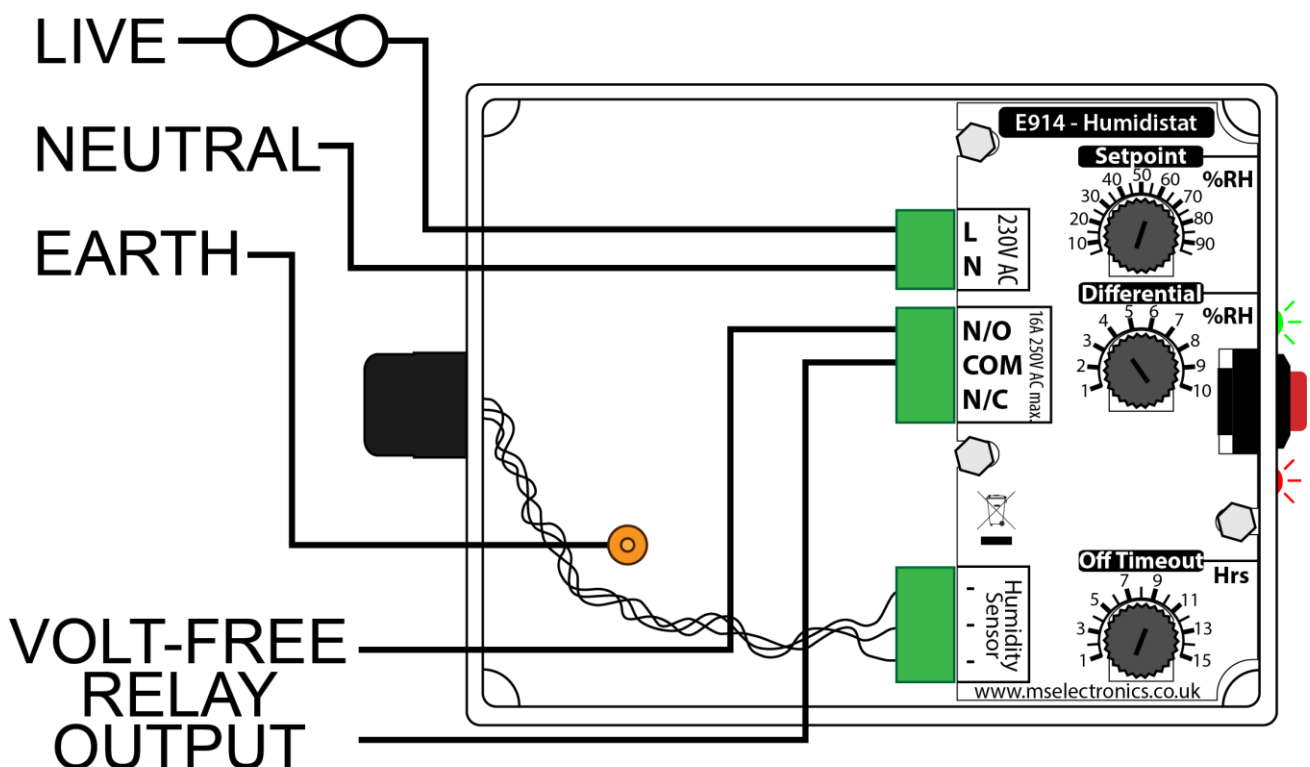

Installation

1. **IMPORTANT:** ensure all electrical connections are isolated before commencing any work on the unit.
2. Unscrew the 4 security screws using MS Electronics tamperproof screwdriver MSD-152 to remove the front cover.
3. Mount the unit securely using any suitable fixing in conjunction with the mounting holes provided in the unit.
4. Connect the wiring as shown in the diagram (or any suitably appropriate form) using the convenient pluggable terminal blocks provided. Make sure to choose the correct output terminals that are suitable to your application (their operation is described in the 'Product Wiring' section).
5. On the remote sensor version, 2-core screened cable should be used to connect the remote sensor to the thermostat. The screen should be connected to the earth terminal ONLY (do not connect the screen to anything at the remote sensor end).
6. Adjust the internal controls to suit the installation operational requirements (see below).
7. Replace the cover securely using the 4 security screws.

Operation

1. **IMPORTANT:** ensure all electrical connections are isolated before commencing any work on the unit.
2. Adjust the "Setpoint" dial to the relative humidity level the room is to be regulated to.
3. Set the "Differential" to the total relative humidity swing either side of the "Setpoint" that the room humidity is required to keep within.
4. Set the "Off Timeout" dial to the number of hours that humidity control can be disabled for before it is automatically re-enabled.
5. Example of a typical set-up:
 - Setpoint set to 55% RH
 - Differential set to 4% RH
 - Off Timeout" set to 10 hoursIn the **ON** mode the unit will maintain the humidity between 53% RH and 57% RH.
The unit will permanently maintain this control unless it is switched **OFF** via the pushbutton.
After 10 hours in the **OFF** mode the E914 will automatically revert back to the **ON** mode.

Technical Specification	
Power supply:	220V - 240V AC 50Hz (live/neutral/earth)
Output switch rating:	16A, 250V AC 50Hz (resistive)
Output switch type:	Changeover relay (volt-free)
Humidity control:	5% RH to 95% RH
Humidity differential:	1% RH to 10% RH
Sensor accuracy:	+/- 3% RH
Sensor drift:	+/- 1.2% RH over 5 years (no calibration required)
Guarantee:	3 Years
Weight:	0.33Kg
Dimensions:	120mm x 95mm x 35mm

IMPORTANT INSTALLATION NOTICE

The installation of this product should be carried out in accordance with the latest IEE wiring regulations and all wiring completed by a qualified electrician.

Technical Support

For further help or information on this and the other products in the MS Electronics range visit www.mselectronics.co.uk or call 0333 666 1176.

Alternatively, email techsupport@mselectronics.co.uk

Additional copies of this product guide can be downloaded from our website.

Product Warranty

MS Electronics guarantees all their products against manufacturing defects for 5 years from the purchase date. If your product is found to be faulty, MS Electronics will, at their discretion, repair or replace the product free of charge.

Note

Any modification or damage to the outer casing of the product, as well as any damage to the product due to abuse or incorrect wiring may invalidate the guarantee.

e: info@mselectronics.co.uk

t: 0333 666 1176/01708 448566

