

Product Guide

Two-Stage Robust Thermostat



today, tomorrow and in the future

mselectronics.co.uk

Product Wiring

- IMPORTANT:** ensure all electrical connections are isolated before commencing any work on the unit.
- Power to the thermostat is provided via the Live and Neutral input terminals labelled “L” and “N” (85 - 265V AC, 50 - 60Hz).
- NOTE:** This thermostat MUST be earthed using the earth terminal provided.
- Two voltage-free relay outputs capable of switching loads of up to 10A, 250V AC (resistive) is provided by the thermostat. The two relays operate as follows:
 - The “FAN” terminal is connected to the “HI” terminal when the sensed room temperature is: Below the temperature “Setpoint” - “2nd Stage”.
Conversely, it is connected to the “LOW” terminal when the sensed room temperature is: Above the temperature “Setpoint” - “2nd Stage”.
 - The “COM” terminal is connected to the “TX” terminal when the sensed room temperature is: Below the temperature “Setpoint”.
Conversely it is disconnected from the “TX” terminal when the sensed room temperature is: Above the temperature “Setpoint”.
- The temperature sensor is factory fitted to all models with the exception of the Remote Sensor (/RS) versions. A 2-core screened cable connection should be made to the “Temp. Sensor” terminals on /RS versions, with the screen connected to the thermostat Earth terminal only.
- CAUTION:** The temperature sensor input is not electrically isolated from the thermostat mains supply and so could possibly be at mains potential. Treat the input with the necessary safety and insulation precautions as if it were at mains potential.

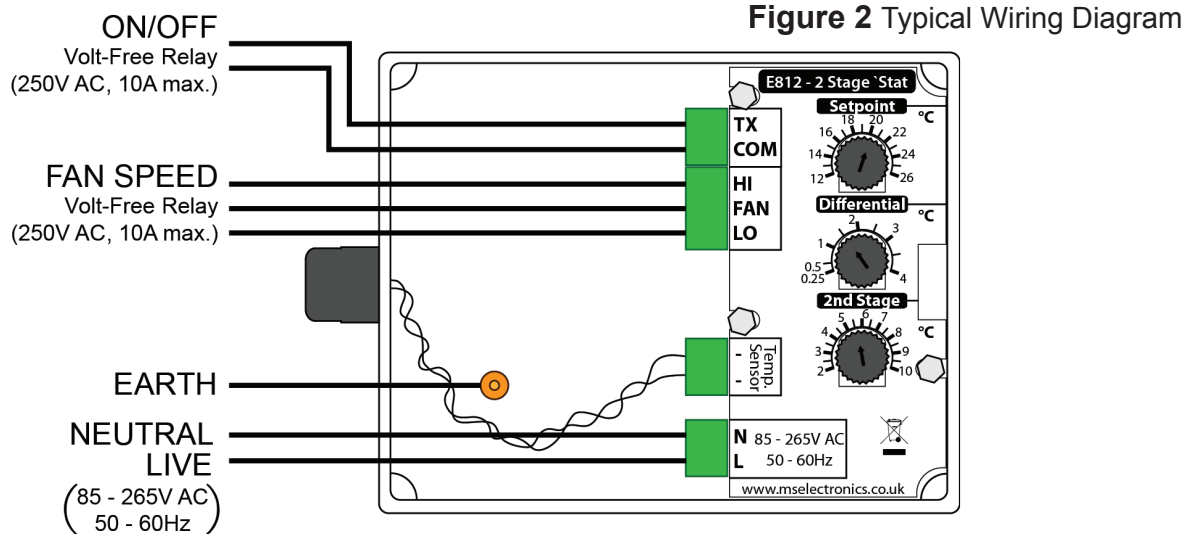

Installation

- IMPORTANT:** ensure all electrical connections are isolated before commencing any work on the unit.
- Unscrew the 4 security screws using M.S. Electronics tamperproof screwdriver MSD-152 to remove the front cover.
- Mount the unit securely using any suitable fixing in conjunction with the mounting holes provided in the unit. For optimal results, position the temperature sensor out of direct sunlight, well away from any heating/cooling sources and approximately 1.5m to 2m from the floor.
- Using Figures 2 to 5 as a guide, connect the wiring in a suitably appropriate form with the convenient pluggable terminal blocks provided. Contact Technical Support with the heater make and model number for specific help if a suitable wiring method is unclear.
- On the remote sensor version (/RS), 2-core screened cable should be used to connect the remote sensor to the thermostat. The screen should be connected to the earth terminal ONLY (do not connect the screen to anything at the remote sensor end).
- Adjust the internal controls to suit the operational requirements (see the ‘Operation’ section).
- Replace the cover securely using the 4 security screws.

Typical Fan Convector Wiring Examples

The diagrams in Figures 3 to 5 illustrate a few generic methods of how to electrically connect the thermostat to a multi-speed fan convector. If you are unsure which of the below diagrams is most suited to your application, please contact our Technical Support team with the specific make and model of heater for further assistance.

Note: The heater may have more than 2 speeds, however the E812 can only control a maximum of 2 speeds (plus 'Off'). When selecting the low fan speed, ensure that in the worst case there is still sufficient heat output to maintain the desired room temperature. A medium speed may need to be selected for the low speed in some cases.

Figure 3: Hot water fan convector (a)

The transformer and the fan are in the same module.
The thermostat routes the Live supply to the correct speed selection terminal on the heater.

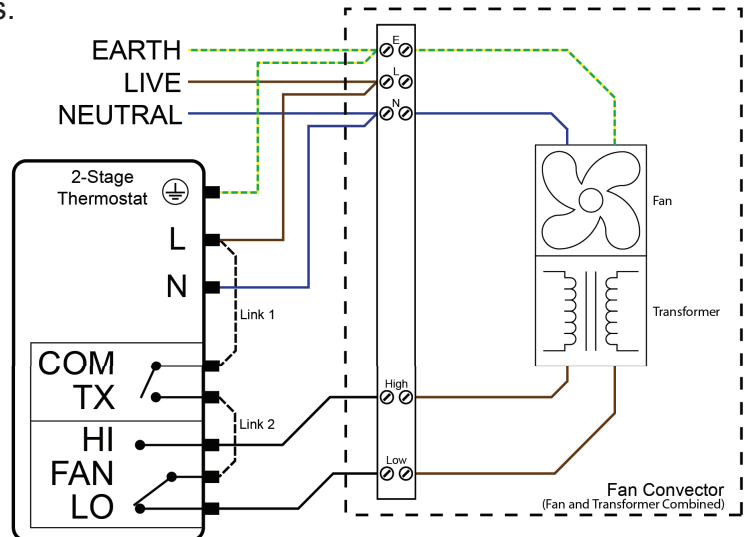

Figure 4: Hot water fan convector (b)

The transformer and the fan are in separate modules.
The transformer has different speed outputs. The thermostat routes the correct speed directly to the fan.

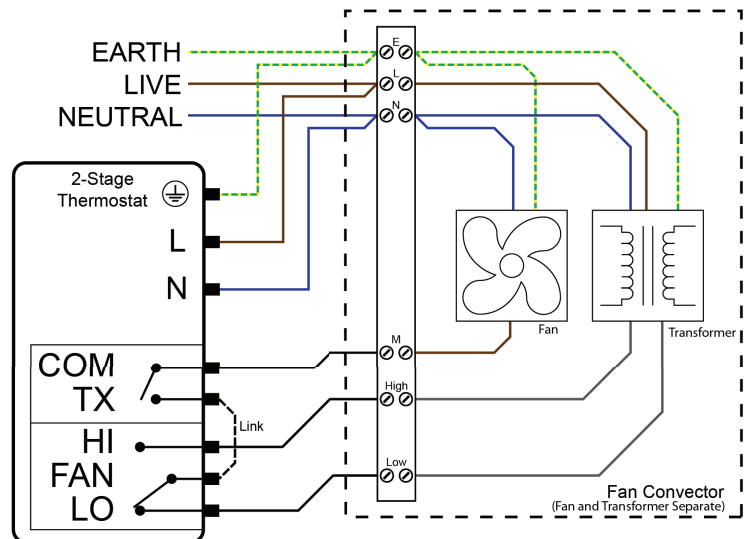
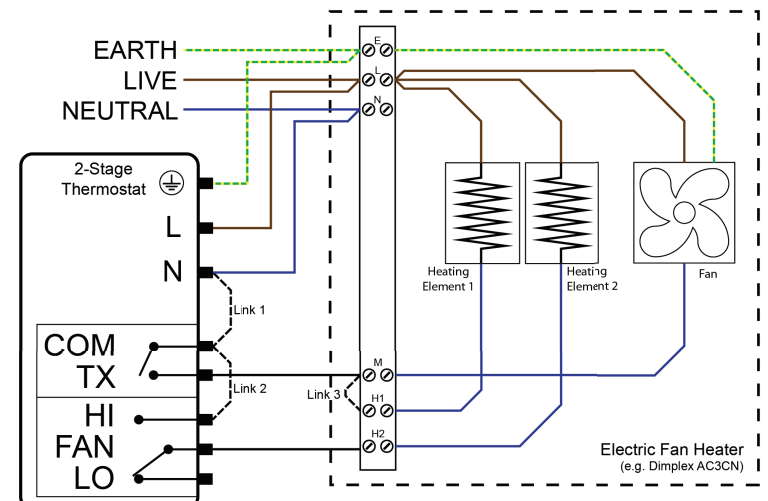

Figure 5: Electric fan convector

Rather than changing fan speeds the thermostat correctly selects either 1 heating element + fan, or 2 heating elements + fan.



Operation

1. **IMPORTANT:** ensure all electrical connections are isolated before commencing any work on the unit.
2. Adjust the “Setpoint” dial to the temperature the room is to be regulated at (typically 21°C).
3. Set the “Differential” to the total temperature swing either side of the “Setpoint” that the room temperature is required to keep within (typically 1°C).
4. Adjust the “2nd Stage” to the temperature below the “Setpoint” that the fan is to automatically change between the High and Low speeds.

Example of a typical set-up:

“Setpoint” set to 22°C, “Differential” set to 1°C and “2nd Stage” set to 4°C.

The unit will maintain the temperature between 21.5°C and 22.5°C.

If the sensed temperature falls below 17.5°C the high fan speed will be selected.

If the sensed temperature rises above 18.5°C the low fan speed will be selected.

If the sensed temperature rises above 22.5°C the fan will be turned off.

Technical Specification	
Power supply:	85-265V AC 50-60Hz (live/neutral/earth)
Output switch rating:	10A, 250V AC (resistive)
Output switch type:	On/Off: Single contact relay (volt-free) High/Low: Changeover relay (volt-free)
Temperature control:	[Setpoint]: +12°C to +26°C [2nd Stage]: 2°C to 10°C below the Setpoint
Temperature differential:	0.25°C to 4°C
2-stage control:	2 speeds (High/Low) + Off
Sensor drift:	0.15°C over 5 years
Guarantee:	5 Years
Weight:	0.34Kg
Dimensions mm:	120mm x 95mm x 35mm

Product Accessories	
MSD-152	M.S. Electronics tamperproof screwdriver
MSD-150	Air temperature sensor (sensor only)
MSD-224	Air temperature sensor (internal, boxed)
MSD-370	Air temperature sensor (internal, faceplate)

Technical Support

For further help or information on this and the other products in the MS Electronics range visit www.mselectronics.co.uk or call 0333 666 1176.

Alternatively, email techsupport@mselectronics.co.uk
Additional copies of this product guide can be downloaded from our website.

Product Warranty

MS Electronics guarantees all their products against manufacturing defects for 5 years from the purchase date. If your product is found to be faulty, MS Electronics will, at their discretion, repair or replace the product free of charge.

Note

Any modification or damage to the outer casing of the product, as well as any damage to the product due to abuse or incorrect wiring may invalidate the guarantee.



e: info@mselectronics.co.uk
t: 0333 666 1176 f: 0333 666 1436



mselectronics.co.uk

MS Electronics reserves the right to alter or change this specification without prior notice.