

Product Guide

Time Delay Switches

3-wire versions

TDS3 Standard
TDS3-L with LED indicator

today, tomorrow and in the future

mselectronics.co.uk

Issue 3.0

Product Overview

The TDS3 Time Delay Switch provides timed switching for lighting, heating, air conditioning and ventilation equipment. The unit features a vandal-resistant touch-sensitive button, offering easy activation of the connected load whilst saving energy by switching it off automatically when not required (after an adjustable period). At any time, the activation period may be extended with a further brief touch, or cancelled by holding momentarily. The unit is available with different time delay ranges (see *Technical Specification*).

- The **TDS3** is a standard time delay switch.
- The **TDS3-L** has an illuminated button to aid location of the unit in the dark.

The unit is simple to install and fits a standard single-gang UK pattress or back box (20mm min. depth). Ideal applications include small booths or rooms, workshops, entrance halls, staircases, toilets, store cupboards, hired sports courts and rooms plus many more.

Figure 1a TDS3



Figure 1b TDS3-L



Figure 2 Typical wiring example and dimensions (in millimetres)

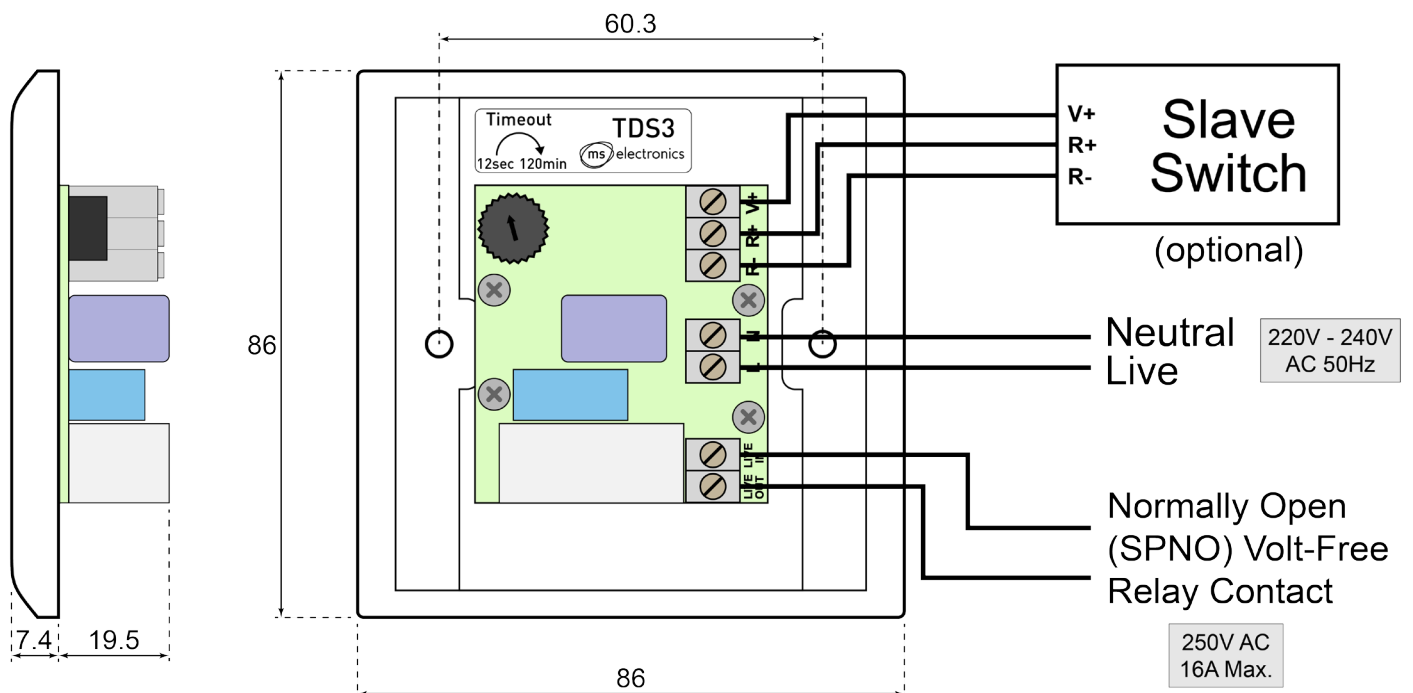

Electrical Requirements

Before attempting to install the unit, ensure that the intended load and wiring arrangement comply with the following requirements. Figure 2 shows a typical wiring example.

- **3-wire (live/neutral + volt-free switch) connection:** The unit requires a permanent live/neutral connection, and as such is *not* suitable for replacing an existing light switch with no neutral conductor at the switch location. A volt-free relay output is provided, which can be used to switch a load on the same mains supply (by connecting across from **L** to **LIVE IN**, making **LIVE OUT** a switched live), or to provide a contact closure to a separate load or control signal. There is no minimum load requirement.

Also available: TDS2 / TDS2-L (2-wire versions) – Suitable for ‘inline’ connection with the load to be switched (no neutral required), such as to replace a standard light switch. A minimum load of **20W (per switch unit)** applies; a load capacitor is required for smaller loads.

- **Maximum load:** The maximum load rating is **16A (4000W)**, however for high inrush loads (such as most types of lighting), a lower limit applies: see *Technical Specification*.

Installation

 All electrical installation and maintenance must be carried out by a competent person. If in doubt, consult a qualified electrician. Any new wiring must be carried out by qualified personnel in accordance with the current edition of the IET Wiring Regulations (BS7671).

 Ensure the electrical supply is isolated before making any connections or adjustments.

1. Prepare a single-gang pattress or back box as necessary.
2. Rotate the **Timeout** thumbwheel (referring to the accompanying label) to set the period of time for which the load should remain switched on after the button is touched.
3. Connect the wiring as shown in Figure 2 (or in any suitably appropriate form).
 - **Supply connections (L, N):** Use appropriate mains cable to power the unit. If the load is also powered via this wiring, ensure the current rating is adequate. Otherwise (i.e. if the output is independently powered), low-current cable may be used.
 - **Load connections (LIVE IN, LIVE OUT):** Use cable rated for the load current and voltage.
 - **Slave switch connections (V+, R+, R-) if required:** Low-current cable may be used but **must be rated for mains voltages**. See *Using Multiple Switches* for wiring details and slave switch options.
4. Fix the unit into position with the two screws and caps supplied.

Additional Guidelines

- The screw caps may be removed at a later date with the aid of an adhesive putty such as Blu-Tack.

Operation

The diagram below illustrates the sequence of operation for the unit.

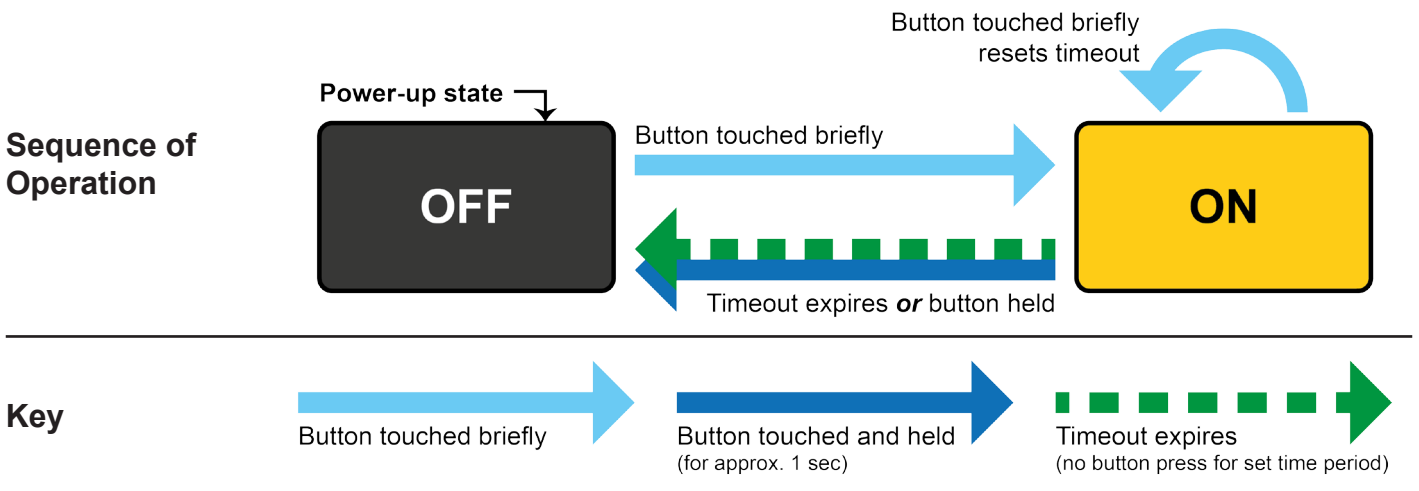

Operation Notes

- **TDS3-L only** In the 'OFF' state, the LED is lit to facilitate location of the unit in the dark.

Using Multiple Switches

To allow the connected load to be controlled from more than one location, multiple switches may be connected, either in parallel, or using lower cost slave switches connected to a single master switch.

⚠ The following wiring examples are intended only as recommendations. Proper wiring practice must be observed with relevance to the particular installation.

Example 1: Parallel Wiring

Figure 3 illustrates a typical wiring arrangement using two TDS3 units; Figure 4 represents the same configuration as applied to a typical ceiling rose lighting circuit. This method can typically reuse pre-existing wiring from a 2-way switching installation where 3-core cable has been run between the switch locations.

Each unit operates its own timing cycle, but the load is shared. When either unit (or both) is activated by its respective touch-sensitive button, the load will switch on. Once *both* units have timed out, the load will switch off. Note that when holding the button to cancel the timeout, the load will remain powered if the other unit is still in the 'ON' state. For full control from any switch location, see *Example 2*.

Figure 3 Typical wiring schematic for two units

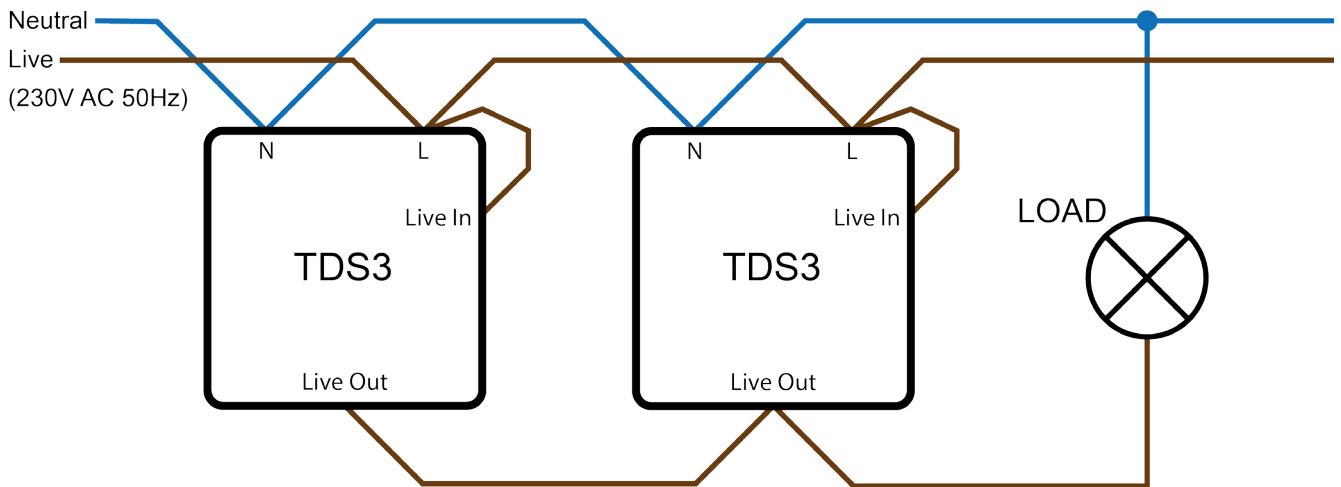
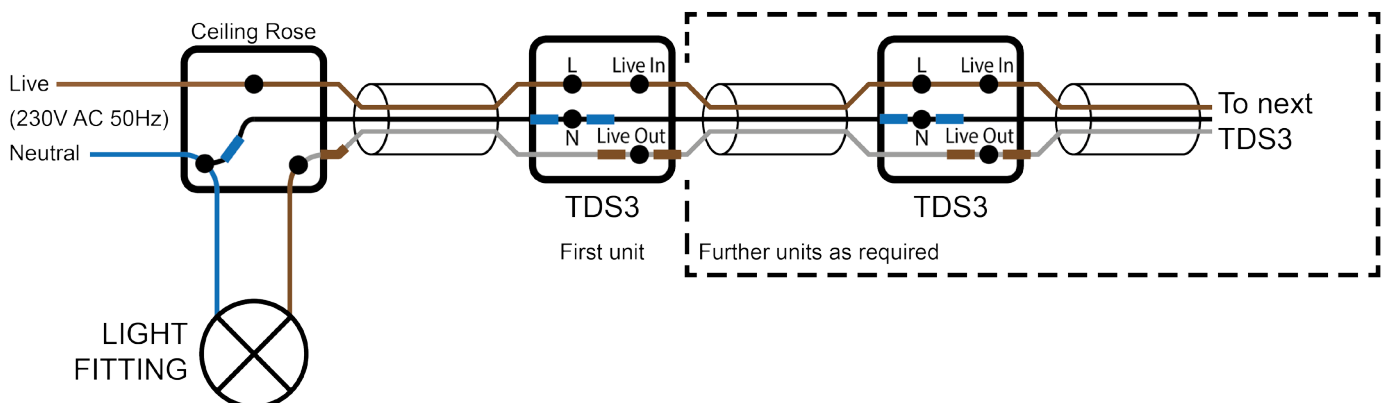

Figure 4 Typical ceiling rose plan



Example 2: Master with Slave Units

The remote interface feature offers the option of lower cost 2-way or multi-way switching by connecting up to five slave switches to a single TDS3 master unit. Unlike parallel wiring (*Example 1*), this method retains full control from any switch location, and does not increase the minimum load requirement. The master unit controls the timing cycle and switches the load, and any of the slave switches will function identically to that on the master unit.

Each slave switch may be either a TDS-S slave unit (which provides an identical touch-sensitive button) or an ordinary normally-open mechanical switch (such as a pushbutton or retractive rocker). Referring to the steps under *Installation*, connect as follows.

- **TDS-S:** Use 3-core mains-rated cable and connect as shown below. Figure 5 illustrates a typical wiring example using two TDS-S slave units; Figure 6 represents the same configuration as applied to a typical ceiling rose lighting circuit.
- **Other switches:** Use 2-core mains-rated cable and connect to the **R+** and **R-** terminals only (polarity does not matter); do not use the **V+** terminal.

 The slave switch connections are referenced to the mains supply of the unit, and are therefore *not* safe to touch when the unit is powered. All switches and cables must be rated for mains voltages.

Figure 5 Typical wiring schematic using two TDS-S slave units

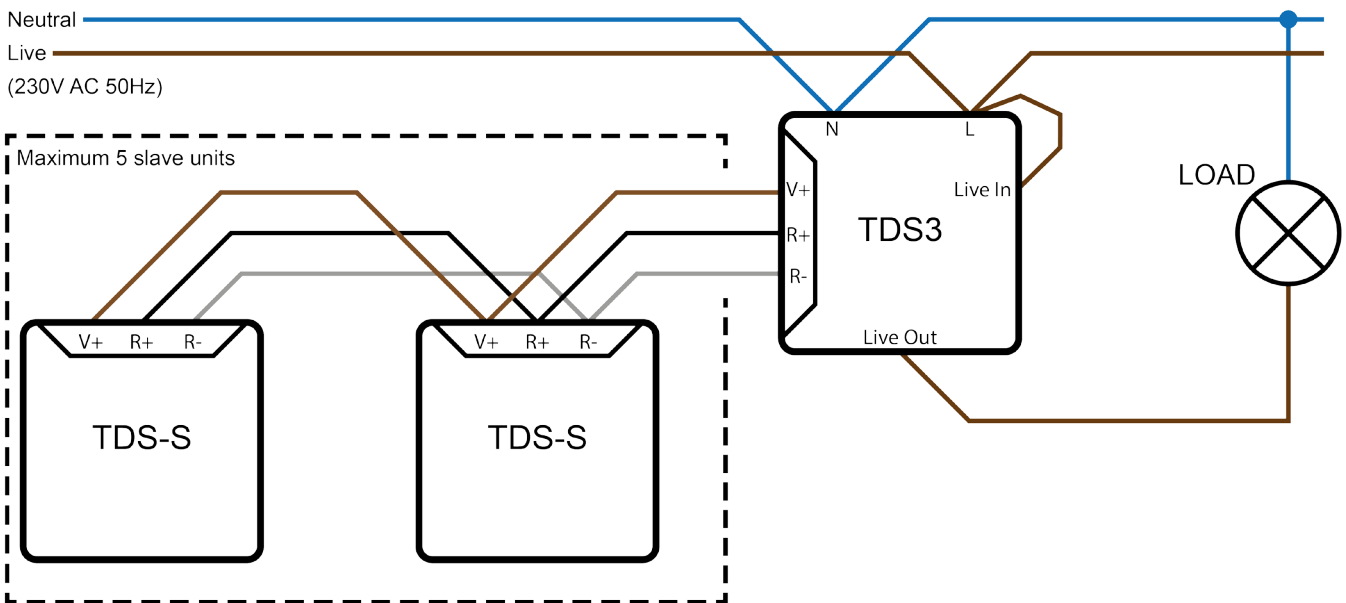
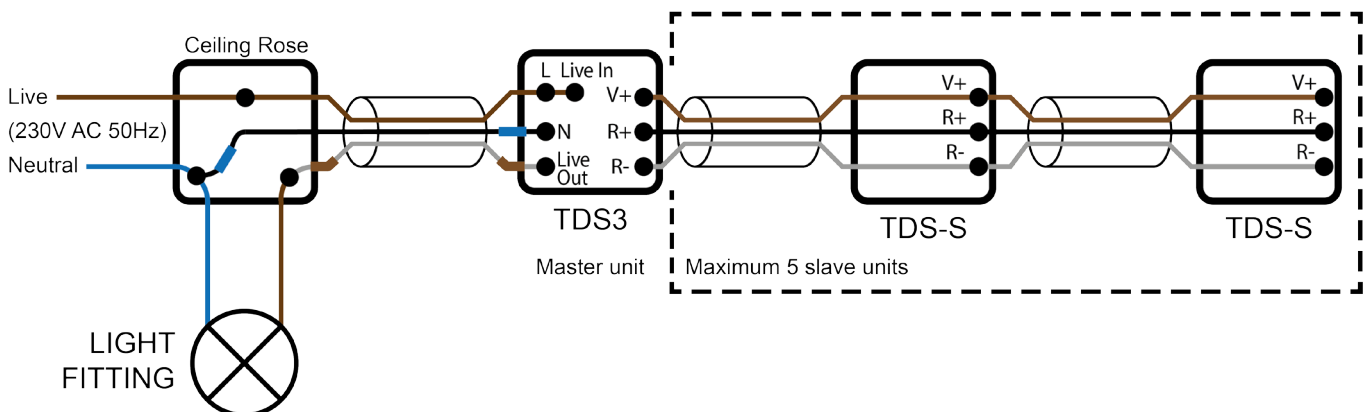

Figure 6 Typical ceiling rose plan using two TDS-S slave units



Fault Finding



Ensure the electrical supply to the unit is isolated before making any adjustments.

Load will not switch on

a) Unit is not powered

- Ensure the unit is correctly connected to an active mains supply.

b) Load is not connected correctly

- Ensure the load is connected appropriately. The relay output is volt-free so must be connected suitably to a supply in order to power a load.
- Check that the load works on its own by bypassing the time delay switch.

Load switches on, but does not switch off

- Ensure the set period has elapsed since the button was last touched.

| Technical Specification | |
|--------------------------------|---|
| Power supply | 220V - 240V AC 50Hz (live/neutral) |
| Output switch type | Volt-free SPST (normally open) relay |
| Output switch rating | 16A, 250V AC (resistive) |
| Maximum lighting load | Incandescent: 12A (3000W) Fluorescent: 10A (2500W) Compact Fluorescent: 10A (2500W) |
| Time delay selection | 3 seconds to 30 minutes or 6 seconds to 60 minutes or 12 seconds to 120 minutes |
| Mounting hardware | 20mm (min.) single-gang UK pattress box |
| Operating temperature | -10°C to +40°C |
| Guarantee | 5 Years |
| Weight | 87g |
| Dimensions | 86mm x 86mm x 27mm |

Technical Support

For further help or information on this and other products in the MS Electronics range visit www.mselectronics.co.uk or call 0333 666 1176.

Alternatively, email techsupport@mselectronics.co.uk
Additional copies of this product guide can be downloaded from our website.

Product Warranty

MS Electronics guarantees all their products against manufacturing defects for 5 years from the purchase date. If your product is found to be faulty, MS Electronics will, at their discretion, repair or replace the product free of charge.

Note

Any modification or damage to the product including damage due to abuse or incorrect wiring may invalidate the guarantee.



e: info@mselectronics.co.uk
t: 0333 666 1176 f: 0333 666 1436



mselectronics.co.uk

Follow us on twitter: [@mselec](https://twitter.com/mselec)

MS Electronics reserves the right to change this specification without prior notice.